

---

---

**ENGINEERING AND DESIGN**

**AIRFIELD RIGID PAVEMENT**

**MOBILIZATION CONSTRUCTION**



---

---

**DEPARTMENT OF THE ARMY**  
**CORPS OF ENGINEERS**  
**OFFICE OF THE CHIEF OF ENGINEERS**

DAEN-ECE-G

Engineer Manual  
No. 1110-3-142

9 April 1984

Engineering and Design  
AIRFIELD RIGID PAVEMENT  
Mobilization Construction

1. Purpose. This manual provides guidance for the design of Army airfield rigid pavement at U.S. Army mobilization installations.
2. Applicability. This manual is applicable to all field operating activities having mobilization construction responsibilities.
3. Discussion. Criteria and standards presented herein apply to construction considered crucial to a mobilization effort. These requirements may be altered when necessary to satisfy special conditions on the basis of good engineering practice consistent with the nature of the construction. Design and construction of mobilization facilities must be completed within 180 days from the date notice to proceed is given with the projected life expectancy of five years. Hence, rapid construction of a facility should be reflected in its design. Time-consuming methods and procedures, normally preferred over quicker methods for better quality, should be de-emphasized. Lesser grade materials should be substituted for higher grade materials when the lesser grade materials would provide satisfactory service and when use of higher grade materials would extend construction time. Work items not immediately necessary for the adequate functioning of the facility should be deferred until such time as they can be completed without delaying the mobilization effort.

FOR THE COMMANDER:



PAUL F. KAVANAUGH  
Colonel, Corps of Engineers  
Chief of Staff

Engineer Manual  
No. 1110-3-142

9 April 1984

Engineering and Design  
AIRFIELD RIGID PAVEMENT  
Mobilization Construction

|            | <u>Paragraph</u>                                      | <u>Page</u> |
|------------|---|-------------|
| CHAPTER 1. | INTRODUCTION  |             |
|            | Purpose and scope.....                                | 1-1 1-1     |
|            | General.....  | 1-2 1-1     |
|            | Definitions and symbols.....                          | 1-3 1-1     |
|            | Investigations preliminary to<br>pavement design..... | 1-4 1-5     |
|            | Subgrade.....   | 1-5 1-5     |
|            | Base courses.....                                     | 1-6 1-7     |
|            | Membrane-encapsulated soil<br>layer (MESL).....       | 1-7 1-8     |
|            | Soil stabilization or<br>modification.....            | 1-8 1-9     |
|            | Evaluation of foundation<br>support.....              | 1-9 1-9     |
|            | Concrete.....   | 1-10 1-10   |
|            | Econcrete.....  | 1-11 1-14   |
| CHAPTER 2. | JOINTED CONCRETE (JC) PAVEMENT<br>DESIGN              |             |
|            | Uses.....   | 2-1 2-1     |
|            | Thickness design curves.....                          | 2-2 2-1     |
|            | Jointing.....   | 2-3 2-1     |
|            | Special joints and junctures...                       | 2-4 2-20    |
| CHAPTER 3. | JOINTED REINFORCED CONCRETE (JRC)<br>PAVEMENT DESIGN  |             |
|            | Uses.....   | 3-1 3-1     |
|            | Reduced thickness design.....                         | 3-2 3-1     |
|            | Reinforcement to control pave-<br>ment cracking.....  | 3-3 3-4     |
|            | JRC pavements in frost areas...                       | 3-4 3-6     |
|            | Reinforcement steel.....                              | 3-5 3-7     |
|            | Jointing.....   | 3-6 3-10    |
| CHAPTER 4. | JOINTED FIBROUS CONCRETE (JFC)<br>PAVEMENT DESIGN     |             |
|            | Basis of design.....                                  | 4-1 4-1     |

|  | <u>Paragraph</u> | <u>Page</u> |
|--|------------------|-------------|
| Uses.....  | 4-2              | 4-1         |
| Mix proportioning considerations.....                                  | 4-3              | 4-1         |
| Thickness determination.....   | 4-4              | 4-2         |
| Allowable deflection for JFC pavement.....                             | 4-5              | 4-2         |
| Jointing.....  | 4-6              | 4-13        |
| <br>CHAPTER 5. OVERLAY PAVEMENT DESIGN                                 |                  |             |
| General.....   | 5-1              | 5-1         |
| Site investigations.....   | 5-2              | 5-1         |
| Preparation of existing pavement.....                                  | 5-3              | 5-1         |
| Condition of existing rigid pavement.....                              | 5-4              | 5-2         |
| Rigid overlay of existing rigid pavement.....                          | 5-5              | 5-4         |
| Rigid overlay of existing flexible or existing composite pavement..... | 5-6              | 5-7         |
| Nonrigid overlay of existing rigid pavement.....                       | 5-7              | 5-7         |
| Overlays in frost regions.....   | 5-8              | 5-9         |
| <br>CHAPTER 6. RIGID PAVEMENT INLAY DESIGN                             |                  |             |
| General.....   | 6-1              | 6-1         |
| Rigid inlays in existing flexible pavement.....                        | 6-2              | 6-1         |
| Rigid inlays in existing rigid pavement.....                           | 6-3              | 6-3         |
| <br>APPENDIX A. REFERENCES   |                  |             |
|  |                  | A-1         |

LIST OF FIGURES

- Figure 1-1. Types of rigid pavement.  
 1-2. Approximate interrelationships of soil classification and bearing values.  
 1-3. Effect of base or subbase thickness on modulus of soil reaction.  
 1-4. Composite modulus of soil reaction.  
 2-1. JC pavement design curves for Army Class I pavements.  
 2-2. JC pavement design curves for Army Class II pavements.  
 2-3. JC pavement design curves for Army Class III pavements.  
 2-4. Pavement design curves for shoulders.

- Figure 2-5. JC pavement design curves for Air Force light-load pavements.
- 2-6. JC pavement design curves for Air Force medium-load pavements.
- 2-7. JC pavement design curves for Air Force heavy-load pavements.
- 2-8. JC pavement design curves for Air Force short field pavements.
- 2-9. Contraction joints for JC pavements.
- 2-10. Construction joints for JC pavements.
- 2-11. Expansion joints for JC pavements.
- 2-12. Typical jointing.
- 2-13. Design of rigid-flexible pavement juncture.
- 3-1. Jointed reinforced concrete pavement design.
- 3-2. Typical layouts showing reinforcement of odd-shaped slabs and mismatched joints.
- 3-3. Reinforcement steel details.
- 3-4. Contraction joints for JRC pavements.
- 3-5. Construction joints for JRC pavements.
- 3-6. Expansion joints for JRC pavements.
- 4-1. Fibrous concrete pavement design curves for Army Class I pavements.
- 4-2. Fibrous concrete pavement design curves for Army Class II pavements.
- 4-3. Fibrous concrete pavement design curves for Army Class III pavements.
- 4-4. Fibrous concrete pavement design curves for Air Force light-load pavements.
- 4-5. Fibrous concrete pavement design curves for Air Force medium-load pavements.
- 4-6. Fibrous concrete pavement design curves for Air Force heavy-load pavements.
- 4-7. Fibrous concrete pavement design curves for Air Force short field pavements.
- 4-8. Deflection curves for Class I pavements.
- 4-9. Deflection curves for Class II pavements.
- 4-10. Deflection curves for Class III pavements.
- 5-1. Condition factor F versus modulus of soil reaction k.
- 6-1. Typical 75-foot-wide rigid pavement inlay in existing flexible pavement.
- 6-2. Typical rigid pavement inlay in existing rigid pavement.

#### LIST OF TABLES

- Table 1-1. Pavement loading classifications.
- 2-1. Recommended spacing of transverse contraction joints.
- 2-2. Dowel size and spacing for construction, contraction, and expansion joints.
- 3-1. Welded wire fabrics.
- 4-1. Limiting elastic deflections for JFC pavements.

## CHAPTER 1

### INTRODUCTION

1-1. Purpose and scope. This manual presents mobilization procedures for the design of Army airfield rigid pavements and overlay pavements that incorporate a portland cement concrete layer in either the overlay or base pavement.

1-2. General. The design procedures presented herein apply to the following types of pavements, design loadings, and design parameters.

a. Types of pavements. A rigid pavement is considered to be any pavement system that contains as one element portland cement concrete, either nonreinforced or reinforced.

b. Design loadings. This manual is limited to Army airfield pavement design requirements for aircraft during a mobilization situation. Discussions and design charts herein are confined to the pavement design classes shown in table 1-1.

c. Design parameters. The procedures in this manual express pavement thicknesses in terms of five principal parameters: design load, generally stated in the design directive; foundation strength; concrete properties; traffic intensity; and traffic areas. The foundation strength and concrete properties normally depend upon many factors that are difficult to evaluate.

1-3. Definitions and symbols. The following terms and symbols are commonly used in this manual. Other more specific or lesser used symbols will be defined where used.

a. Definitions.

(1) Base pavement. The existing pavement (either rigid or flexible) on which an overlay is to be placed.

(2) Inlay pavement. Rigid pavement used to replace the interior width of existing runways and as a method of rehabilitation or upgrading of existing pavement.

(3) Stabilized soil. The improvement of the load-carrying and durability characteristics of a soil through the use of admixtures. Lime, cement, and fly ash, or combinations thereof, and bitumens are the commonly used additives for soil stabilization.

(4) Modified soil. The use of additives to improve the construction characteristics of a soil. However, the additives do not improve the strength of the soil sufficiently to qualify it as a stabilized soil.

9 Apr 84

Table 1-1. Pavement Loading Classifications\*

| Class | Planned Aircraft Traffic  | Design Basis   |
|-------|---|--|
| I     | Rotary- and fixed-wing aircraft with maximum gross weights equal to or less than 20,000 pounds.                                       | Class I pavement will accommodate all Army fixed-wing and rotary wing aircraft except the CH-47B/C, CH-54A/B and the proposed Heavy Lift Helicopter. This pavement design will be used for all airfield facilities other than where Class II, III, or IV pavement design is required. The design is based on 25,000 passes of the most critical aircraft in this class.  |
| II    | Rotary-wing aircraft with maximum gross weights between 20,001 and 50,000 pounds.   | Class II pavement design will be used for facilities designated to accommodate the CH-47B/C and CH-54A/B aircraft. The design is based on 25,000 passes of the most critical aircraft in this class.   |
| III   | Fixed-wing aircraft with maximum gross weights between 20,001 and 175,000 pounds and having one of the indicated gear configurations. | Class III pavement design is suitable for a large number of fixed-wing aircraft currently in inventory. The design is based on 5,000 passes of the most critical aircraft in this class. Design criteria relates only to aircraft having one of the following gear configurations:<br><br>Single wheel, tricycle, 100 psi tire pressure.<br><br>Twin wheel, tricycle, 28-inch c. to c. spacing, 226 square inches contact area each tire.  |
| IV    | Multiple wheel fixed-wing and rotary-wing aircraft other than those considered for Class III pavement.                                | Class IV pavement will be of special design based on gear configuration and gear loads of the most critical aircraft planned to use the facility. Class IV pavement design will also be used for facilities normally being designed as Class III pavements when over 5,000 passes of the most critical aircraft in that category are anticipated during the expected life of the pavement. Designs for special gear configurations shall be based on design curves provided in Air Force Manuals. Curves for Air Force Light, Medium, Heavy load and short field are included for reference. |

\* Type B traffic areas include all runways, primary taxiways, warmup aprons, and traffic lanes across parking aprons. Type C traffic areas include shoulders, overruns, secondary (ladder) taxiways, parking aprons except for traffic lanes, and other paved areas used by aircraft not included in Type B traffic areas. Type A and D traffic areas will not be considered for Class I, II, and III pavement loadings under mobilization design criteria.

U. S. Army Corps of Engineers

9 Apr 84

(5) CE maximum density. The measure of a soil density described in MIL-STD-621, Test Method 100.

(6) Traffic areas. Areas used to divide pavement into groupings in accordance with traffic usage.

(7) Aircraft pass. The passage of an aircraft on the pavement facility being designed.

(8) Design aircraft pass level. The number of aircraft passes for which an airfield is to be designed.

(9) Coverage. A measure of the number of maximum stress repetitions that occur at a particular location in a pavement as a result of the design aircraft pass level.

(10) Pass-per-coverage ratio. The number of passes required to produce one coverage.

(11) Jet fuel resistant (JFR) materials. Materials, such as pavement joint fillers, which are designed to resist the effects of fuels used in jet-operated aircraft.

b. Symbols. A graphic representation of typical pavement symbols can be found in figure 1-1.

|           |  |
|-----------|--|
| $A_p$     | Cross-sectional area of pavement, square inches, per foot of pavement width or length  |
| $A_s$     | Cross-sectional area of reinforcing steel, square inches, per foot of pavement width or length   |
| $b$       | Thickness of nonstabilized base course, inches   |
| $c, r, f$ | Subscripts used to denote that the thickness of rigid pavement is concrete (JC), reinforced concrete (JRC), or fibrous concrete (JFC), respectively (i.e., $h_{dc}$ denotes required thickness of JC pavement on subgrade or unbound base) |
| $C$       | Condition factor based upon structural condition of existing rigid pavement immediately prior to application of an overlay for strengthening purposes  |
| CBR       | California Bearing Ratio, determined in accordance with MIL-STD-621, Test Method 101   |



9 Apr 84

- $E_f$  Static modulus of elasticity in flexure, psi (Note: subscripts c and s used to denote concrete and stabilized material or Econocrete, respectively)
- $f_s$  Yield strength of reinforcing steel bar or wire, psi
- F Factor relating controlled degree of cracking allowed in the existing pavement after a nonrigid overlay has been applied
- $h_b$  Thickness of stabilized layer or Econocrete in overlay design, inches
- $h_d$  Required design thickness of new rigid pavement, inches
- $h_e$  Thickness of existing rigid pavement, inches
- $h_o$  Required thickness of new rigid pavement overlay, inches
- $h_E$  Equivalent thickness of rigid pavement, inches
- k Modulus of soil reaction, psi per inch, determined in accordance with MIL-STD-621, Test Method 104 (Note: subscripts s, b, and n often used to denote value on surface of subgrade, base course, or existing flexible pavement, respectively)
- $k_c$  Composite modulus of soil reaction, psi per inch, of layered system containing stabilized soil determined as described herein
- L Length of rigid pavement slab, feet
- LL Liquid limit of soil as determined by MIL-STD-621, Test Method 103
- PI Plasticity index of soil as determined by MIL-STD-621, Test Method 103
- PL Plastic limit of soil as determined by MIL-STD-621, Test Method 103
- R Flexural strength of concrete, pounds per square inch, determined in accordance with ASTM C 78
- S Percentage of reinforcing steel in a reinforced pavement  
 $= A_s/A_p \times 100$
- $t_d$  Required thickness of flexible pavement based upon subgrade CBR

9 Apr 84

$t_o$  Required thickness of nonrigid overlay, inches (Note: subscripts  $f$  and  $a$  used to denote flexible or all-bituminous concrete nonrigid overlay, respectively)

$W$  Width of rigid pavement slab, feet

1-4. Investigations preliminary to pavement design. The designer should take advantage of all available existing information on subsurface conditions. Existing boring logs and test data previously taken in the area could give insight into these conditions. Insofar as time allows, conventional explorations and laboratory classification tests should be employed. These tests are similar to those described in MIL-STD-619 and MIL-STD-621. They will be used as appropriate to establish the pertinent soil characteristics and any peculiarities of the proposed site that might affect the behavior of the pavement.

#### 1-5. Subgrade.

a. Exploration. Data from available borings, test holes, test pits, etc., should be used to the advantage possible. As a minimum, the site should be visually inspected for obviously defective soil conditions. Undesirable material such as peat, wet clays or silts, quicksand, or other non-supportive soils will be excavated and replaced with material acceptable for subgrade or base course material. In order to give consideration to all factors that may affect the performance of the pavement, a study of existing pavements on similar subgrades in the locality should be made to determine the conditions that may develop in the subgrade after it has been used under a pavement. The engineer is cautioned that such factors as ground water, surface water infiltration, soil capillarity, topography, drainage, rainfall, and frost conditions may affect the future support rendered by the prepared subgrade or base course. Experience has shown that the subgrade will reach near saturation, even in semiarid and arid regions, after a pavement has been constructed. If conditions exist that will cause the subgrade soil to be affected adversely by frost action, the subgrade will be treated in accordance with the requirements of EM 1110-3-138.

b. Compaction requirements. Subgrade soils that gain strength when remolded and compacted will be prepared in accordance with the following criteria.

(1) Compacting fill sections. All fill sections should be compacted to 95 percent of CE maximum density for cohesionless materials and 90 percent for cohesive materials.

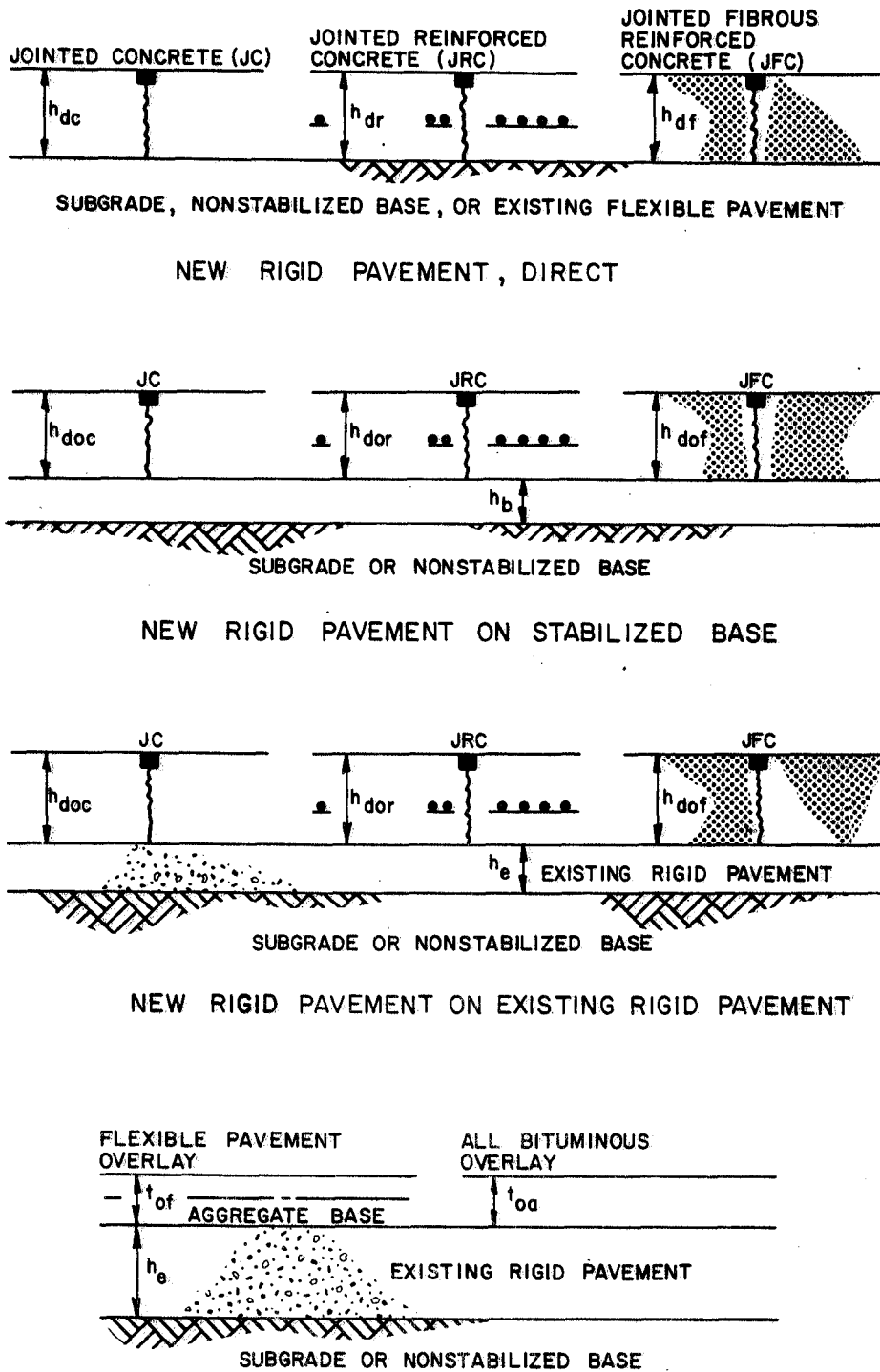

ASPHALTIC OVERLAY ON EXISTING RIGID PAVEMENT

U. S. Army Corps of Engineers

FIGURE 1-1. TYPES OF RIGID PAVEMENTS

(2) Compacting cut sections. The top 6 inches of all subgrades should be compacted to not less than 90 percent of CE maximum density for cohesive materials and 95 percent for cohesionless materials.

1-6. Base courses. Base courses may be required for one or more of the following reasons: to provide uniform bearing surface for the pavement slab; to replace soft, highly compressible, or expansive soils; to protect the subgrade from detrimental frost heaving; to produce a suitable surface for operating construction equipment during unfavorable weather; to improve the foundation strength (modulus of soil reaction or modulus of elasticity); to prevent subgrade pumping; and to provide drainage of water from under the pavement. When required, a minimum base course thickness of 4 inches will be applied over subgrades. Engineering judgment must be exercised in the design of base course drainage to insure against the trapping of water directly beneath the pavement, which invites the pumping condition that the base course is intended to prevent. Care must also be exercised when selecting base course materials to be used with slipform construction of the pavement. Generally, slipform pavers will operate satisfactorily on materials meeting the base course requirements in paragraph 1-6a. However, cohesionless sands, rounded aggregates, etc., may not provide sufficient stability for slipform operation and should be avoided if slipform paving is to be a construction option.

a. Material requirements. An investigation will be made to determine the source, quantity, and characteristics of available materials. The base course may consist of natural materials or processed materials. In general, the unbound base material will be a well-graded, high-stability material. All base courses to be placed beneath airfield rigid pavements will conform to the following requirements (sieve designations are in accordance with ASTM E 11):

- Well-graded, coarse to fine.
- Not more than 85 percent passing the No. 10 sieve.
- Not more than 15 percent passing the No. 200 sieve.
- PI not more than 8 percent.

However, when it is necessary that the base course provide drainage, the requirements set forth in EM-1110-3-136 will be followed.

b. Compaction requirements. High densities are essential to keep future consolidation to a minimum; however, thin base courses placed on yielding subgrades are difficult to compact to high densities. Therefore, the design density in the base course materials should be the maximum that can be obtained by practical compaction procedures in the field but not less than:

9 Apr 84

(1) 95 percent of CE maximum density for base courses less than 10 inches thick.

(2) 100 percent of CE maximum density in the top 6 inches and 95 percent of CE maximum density for the remaining thickness for base courses 10 inches or more in thickness.

1-7. Membrane-encapsulated soil layer (MESL). Fine-grained soils that are well compacted at moisture contents below optimum exhibit high strength and low deformability. The MESL is a technique to assure the permanence of these desirable properties by preserving the moisture content at its initial low value. The MESL consists of a layer of compacted fine-grained soil encapsulated in a waterproof membrane that may be used as a foundation for a pavement structure.

a. Materials. The components of the encapsulating membrane normally include polyethylene sheeting, polypropylene fabric, emulsified asphalt, and blotter sand. Sheets of 6-mil or greater thickness of polyethylene are suitable for use as the bottom and sides of the encapsulation. Emulsified asphalt, Grade CSS-1h or SS-1h for warm or hot climates and Grade CRS-2 or RS-2 for cold climates, is used as the prime coat. Polypropylene fabric, emulsified asphalt, and sand are used for the upper membrane to withstand traffic during construction. These materials have been used successfully; however, other materials are available and may be preferred.

b. Construction. Either the in-place or select material can be encapsulated and serve as a subbase or base course material. If the in-place material is to be encapsulated, it must first be removed to the desired depth of encapsulation and windrowed. Subsequent operations are the same for in-place or select materials. MESLs can be constructed in any widths or lengths desired by overlapping sheets of membrane. Laps in the polyethylene should be overlapped a minimum of 2 feet and sealed with emulsified asphalt. Laps in the polypropylene fabric should be overlapped a minimum of 1 foot and sealed with asphalt. The surface on which the membrane is placed should be spray-coated with emulsified asphalt, which will act as an anchor to hold the fabric in place as well as seal for small punctures. Large punctures, rips, or tears in the fabric must be repaired by applying asphalt and covering with membrane. The stockpiled soil is placed on the bottom membrane, taking care that equipment is always operating on a minimum of 10 inches of loose soil. The soil is placed at a moisture content slightly below optimum (2 percent plus or minus 1 percent) and compacted to a minimum of 95 percent CE maximum density. Following fine grading, the surface is sprayed with 0.25 to 0.05 gallon per square yard of asphalt and the polypropylene fabric applied. A final application of 0.2 to 0.3 gallon of asphalt is applied to the fabric and blotted with a dry sand passing the No. 4 sieve. A seal at the edges is obtained by overlapping the polyethylene with the

9 Apr 84

polypropylene for a distance of at least 1 foot and using asphalt between the membranes.

1-8. Soil stabilization or modification. The stabilization or modification of the subgrade and/or base course materials using either chemicals or bitumens has been found desirable in many geographic areas. Principal benefits include the following: reduces rigid pavement thickness requirements; provides a stable all-weather construction platform; decreases swell potential; and reduces the susceptibility to pumping as well as the susceptibility of strength loss due to moisture. Normally, the decision to stabilize or modify a soil will be based upon the time restrictions and materials availability involved.

a. Requirements. To qualify as a stabilized layer (i.e., permit reduction in rigid pavement thickness requirement), the stabilized material must meet the unconfined compressive strength and durability requirements contained in EM 1110-3-137. Otherwise, the layer is considered to be a modified soil. The design of the stabilization or modification will be in accordance with EM 1110-3-137 and EM 1110-3-138. Pavement designs that result in a nonstabilized (pervious) layer sandwiched between a stabilized or modified soil (impervious) layer and the pavement present the danger of entrapped water with subsequent instability in the nonstabilized layer. These designs will not be used unless the nonstabilized layer is positively drained.

b. Evaluation. The foundation support provided by modified soil layers will be evaluated by the modulus of soil reaction  $k$  determined after the modifying agent has been added using the procedure outlined in paragraph 1-9. For stabilized soils, the evaluation of the supporting value will depend upon the type of pavement being designed. For example, for JC, JRC, and JFC pavements, the stabilized layer will be considered to be a low-strength base pavement, and the design will be accomplished using a modification of the partially bonded rigid overlay equation as described in chapters 2, 3, and 4. The thickness and flexural modulus of elasticity  $E_{fs}$  of the stabilized material will be determined at the same age as for the design flexural strength of the concrete (para 1-10). The flexural modulus of elasticity of cement-, lime-, and fly-ash-stabilized material will be determined in accordance with EM 1110-3-135; for bituminous-stabilized material the flexural modulus will be determined in accordance with EM 1110-3-141. Estimate flexural modulus values if time is not available for testing.

1-9. Evaluation of foundation support.

a. Modulus of soil reaction  $k$ . The modulus of soil reaction  $k$ , expressed in psi per inch, will be used to define the supporting value of all unbound subgrade and base course materials and all soils that have been additive-modified or encapsulated. The  $k$  value will be

9 Apr 84

determined by the field plate bearing test as described in MIL-STD-621, Test Method 104 or estimated from figure 1-2.

(1) Subgrade. The field plate bearing test will be performed on representative areas of the subgrade, taking into consideration such things as changes in material classification, fill or cut areas, and varying moisture (drainage) conditions, which would affect the support value of the subgrade. When it is not practical to perform field plate bearing tests to make a statistical analysis of the  $k$  value, a value from figure 1-2 should be assigned. The pavement thickness is not affected appreciably by small changes in  $k$  values; therefore, the value need not be sharply defined. Normally, bracketed values will suffice, and the assignment of  $k$  values should be in increments of 10 psi per inch for values up to and including 250 psi per inch and increments of 25 psi per inch for values exceeding 250 psi per inch. A maximum  $k$  value of 500 psi per inch will be used.

(2) Base courses. The modulus of soil reaction  $k$  of unbound base courses will be determined from figure 1-3. The value obtained will be used for the pavement design. Figure 1-3 yields an effective  $k$  value at the surface of the base or subbase as a function of the subgrade  $k$  value and base or subbase thickness.

b. Composite modulus of soil reaction  $k_c$ . For the design of pavements requiring a stabilized layer directly under the pavement, the foundation strength will be defined as a composite modulus of soil reactions  $k_c$ . The  $k_c$  value is a function of the modulus of soil reaction  $k$  of the foundation materials directly beneath the stabilized layer and the thickness and flexural modulus of elasticity of the stabilized layer. With these properties, the  $k_c$  value is determined from figure 1-4.

c. Foundation support in frost areas. The procedure for evaluating foundation support in frost areas is presented in EM 1110-3-138.

#### 1-10. Concrete.

a. Stresses. The design of a concrete pavement is based on the critical tensile stresses produced within the slab by the aircraft loading. However, a common and sometimes important source of stress is temperature and/or moisture differential within the slab. The location and intensity of critical stresses produced by a wheel load will vary from point to point depending on the location of the load. The critical concrete tensile stress occurs when the load is adjacent to an edge or joint of the pavement. The stress due to temperature and moisture variation reverses cyclically from top to bottom and may add to or subtract from the stress due to the applied load. Although not

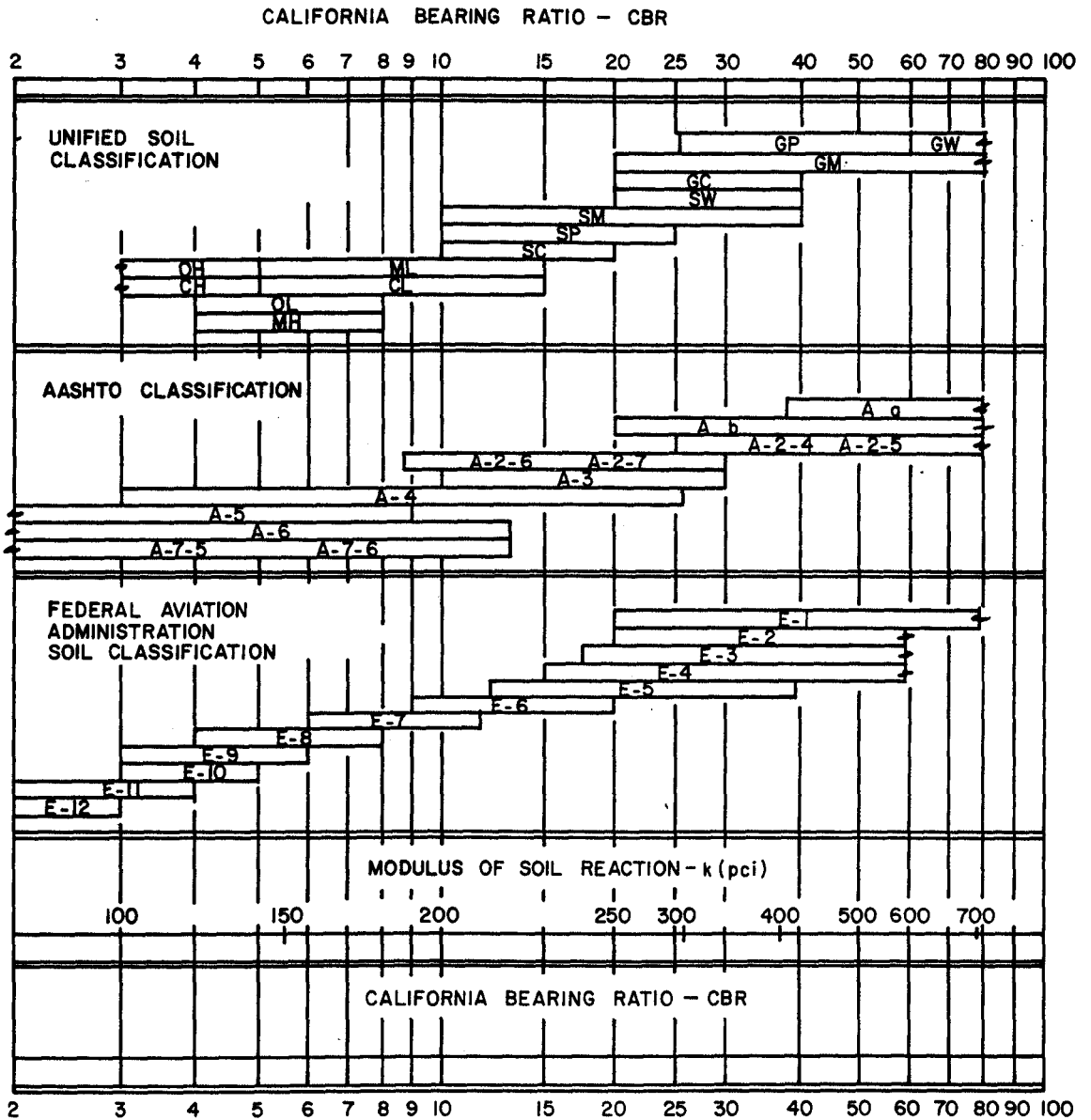

PCA Soil Primer (EB007.068), With Permission of the Portland Cement Association, Skokie, IL.

FIGURE 1-2. APPROXIMATE INTERRELATIONSHIPS OF SOIL CLASSIFICATION AND BEARING VALUES



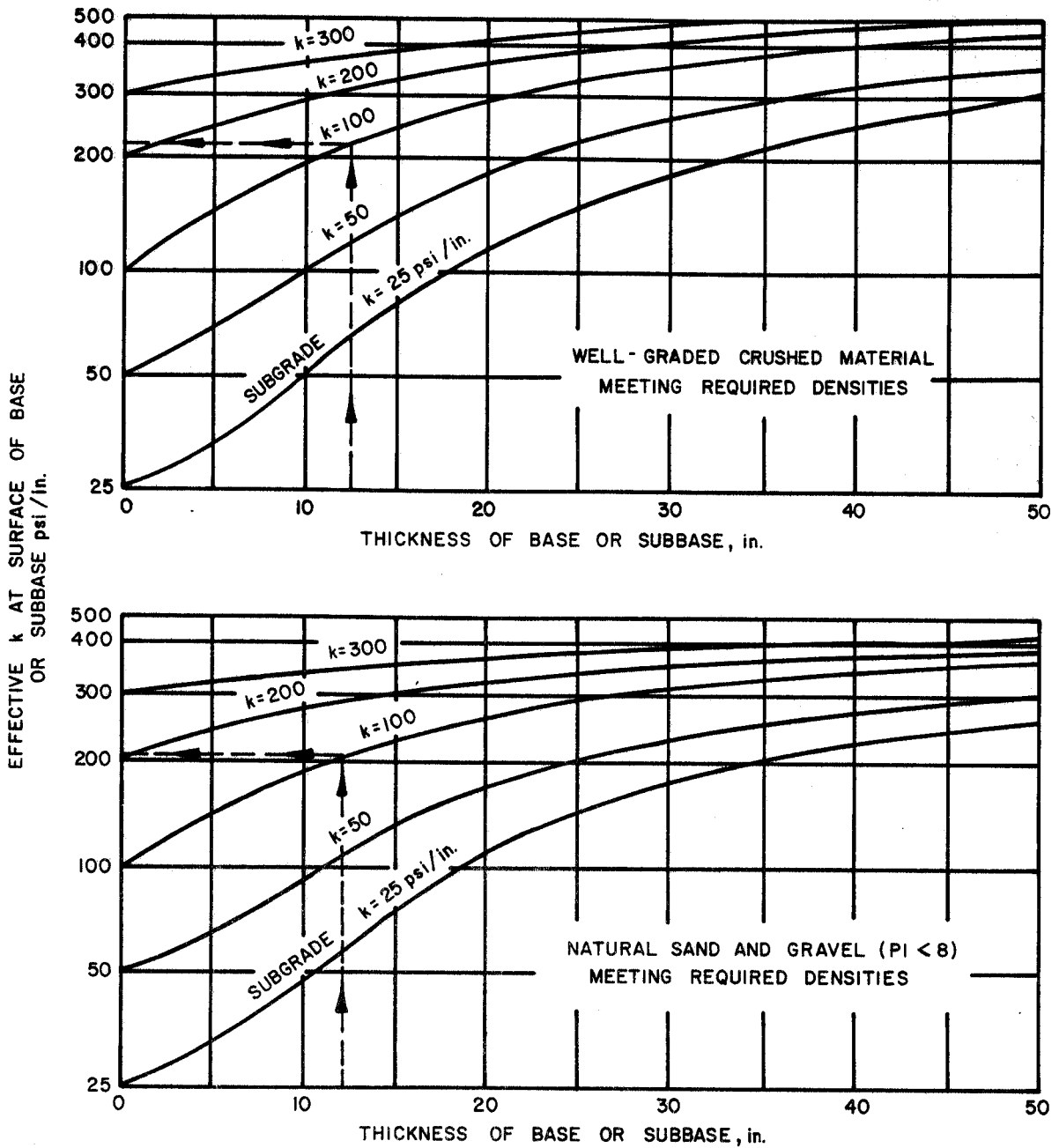

U. S. Army Corps of Engineers

FIGURE 1-3. EFFECT OF BASE OR SUBBASE THICKNESS ON MODULUS OF SOIL REACTION

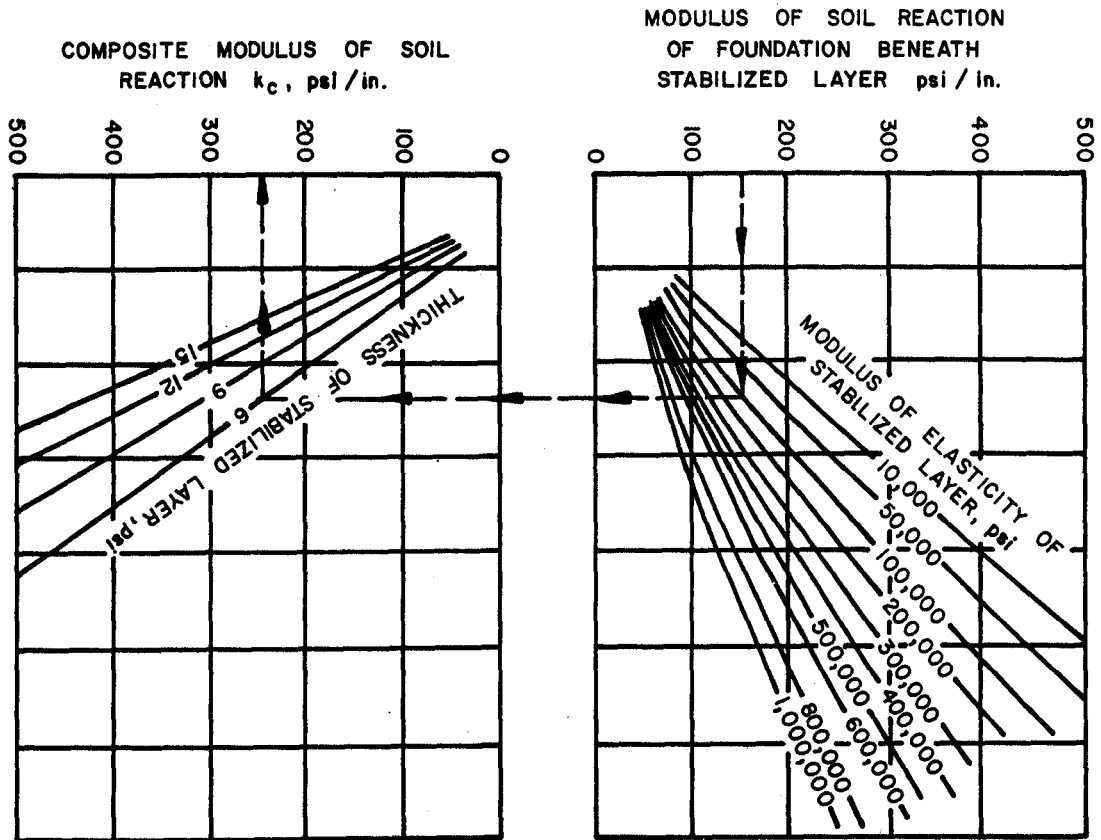

U. S. Army Corps of Engineers

FIGURE 1-4. COMPOSITE MODULUS OF SOIL REACTION

9 Apr 84

considered independently, the overall effect of these cyclic stresses has been considered in the thickness criteria presented herein.

b. Mix proportioning and control. Proportioning of the concrete mix and control of the concrete for pavement construction will be in accordance with EM 1110-3-135. Normally, a design flexural strength at 90-day age will be used for pavement thickness determination. Should it be necessary to use the pavements at an earlier age, consideration should be given to the use of a design flexural strength at the earlier age or to the use of high early-strength cement, whichever is most feasible.

c. Testing. The flexural strength and modulus of elasticity in flexure of the concrete (and Econocrete) will be determined in accordance with ASTM C 78. The test specimen will be a 6- by 6-inch section long enough to permit testing over a span of 18 inches. When aggregate larger than the 2-inch nominal size is used in the concrete, the mix will be wet-screened over a 2-inch-square mesh sieve before it is used for casting the beam specimen.

1-11. Econocrete. Econocrete is a name given to concrete utilizing locally available crusher-run or natural aggregates. Econocrete may be used as a base course for rigid pavement and may be considered for shoulders or overrun pavements providing the Econocrete can be demonstrated to have the required durability. The mix proportioning, control, and testing of Econocrete will be the same as for concrete (para 1-10). Since Econocrete is designed specifically to provide economy in pavement construction, emphasis must be placed on economy when arriving at the design mix proportioning. Admixtures can be used in Econocrete to increase workability, strength, and durability in the same manner as they are used for concrete. Cement contents in the 225 to 375 pounds per cubic yard range yield economical mixes with good workability. When used as a base course for rigid pavement, the Econocrete will be considered as a stabilized layer and must exhibit the required strength and durability of a stabilized layer. The evaluation of the foundation support provided by the Econocrete will be accomplished in accordance with paragraph 1-8.

## CHAPTER 2

## JOINTED CONCRETE (JC) PAVEMENT DESIGN

2-1. Uses. JC pavement, meeting the requirements contained herein, can be used for any pavement facility. The only restriction to the use of JC pavement pertains to unusual conditions that may require minimal reinforcement of the pavement as outlined in chapter 3.

2-2. Thickness design curves. Figures 2-1 through 2-3 are design curves for design Classes I, II, and III defined in table 1-1. Figure 2-4 is a design curve for shoulder pavements applicable to all design classes. (Curves for Air Force light, medium, heavy loads, and short field, figures 2-5 through 2-8, are included for reference.)

a. JC pavements on nonstabilized or modified soil foundations. For JC pavements that will be placed directly on nonstabilized or modified base courses or subgrade, the thickness requirement  $h_{dc}$  will be determined from the appropriate design curve using the design parameters of concrete flexural strength  $R$ , modulus of soil reaction  $k$ , gross weight of aircraft, aircraft pass level, and pavement traffic area type (except the shoulder design). When the thickness from the design curve indicates a fractional value, it will be rounded to the nearest full- or half-inch thickness. Values falling exactly on 0.25 or 0.75 inch will be rounded upward. Pavement thickness may be modified within narrow limits by the use of higher flexural strengths, stabilized layers (b below) to increase the foundation supporting value, or by the addition of reinforcing steel. When it is necessary to change from one thickness to another within a pavement facility, such as from one type traffic area to another, the transition will be accomplished in one full paving lane width or slab length.

b. JC pavements on stabilized base and/or subbase. Stabilized base and/or subgrade layers meeting the strength requirements of paragraph 1-8a and Econcrete will be treated as low-strength base pavements, and the JC pavement thickness will be determined using the following modified, partially bonded rigid overlay pavement design equation:

$$h_{doc} = \sqrt[1.4]{h_{dc} - (0.0063 \sqrt[3]{E_{fc}} h_b)^{1.4}}$$

The required thickness determined by this equation will be rounded to the nearest full- or half-inch thickness for construction. Values falling midway between the half and full inch will be rounded upward.

2-3. Jointing. Joints are provided to permit contraction and expansion of the concrete resulting from temperature and moisture changes, to relieve warping and curling stresses due to temperature and moisture differentials, to prevent unsightly irregular breaking of the pavement, and as a construction expedient to separate sections or

9 Apr 84

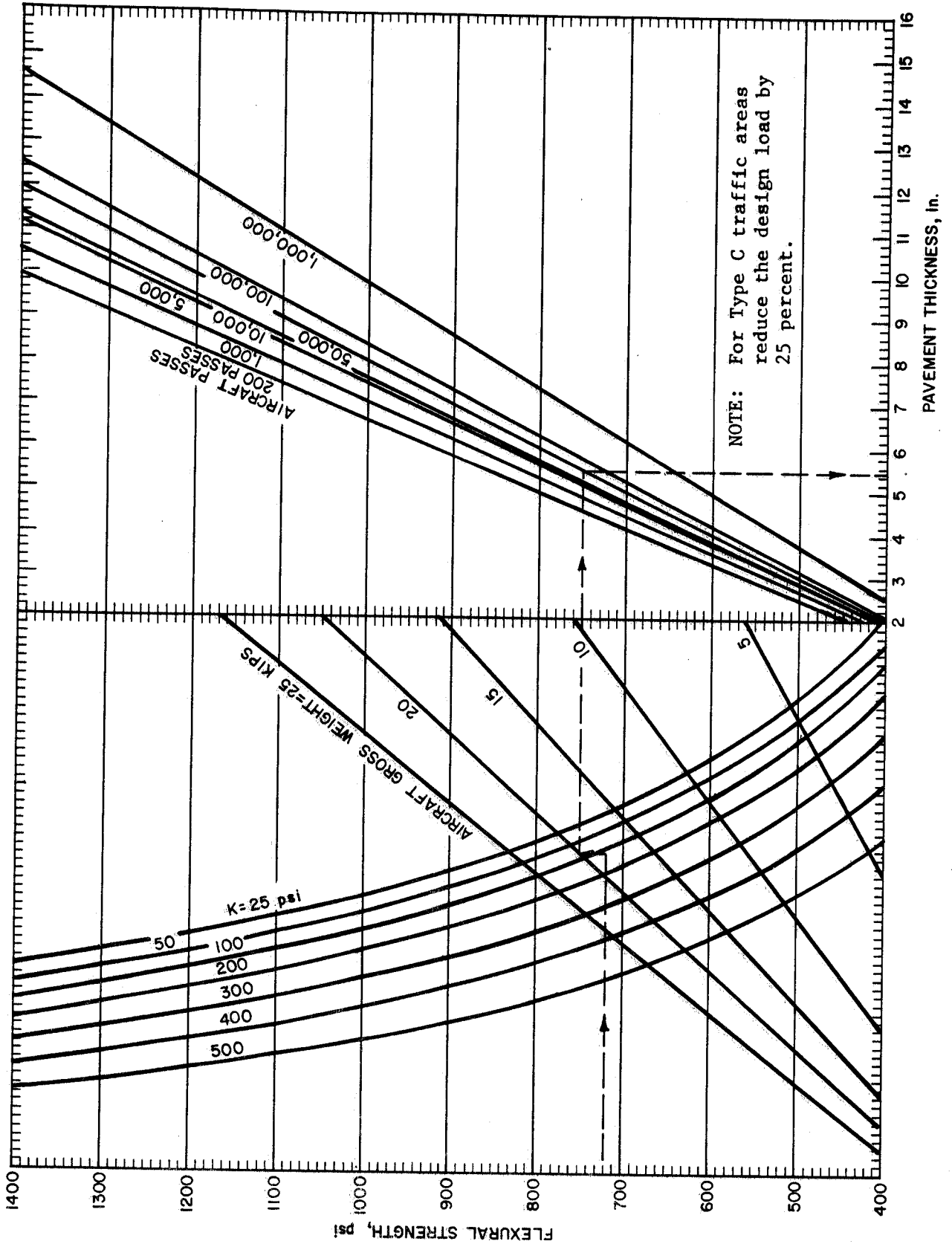

U. S. Army Corps of Engineers

FIGURE 2-1. JC PAVEMENT DESIGN CURVES FOR ARMY CLASS I PAVEMENTS

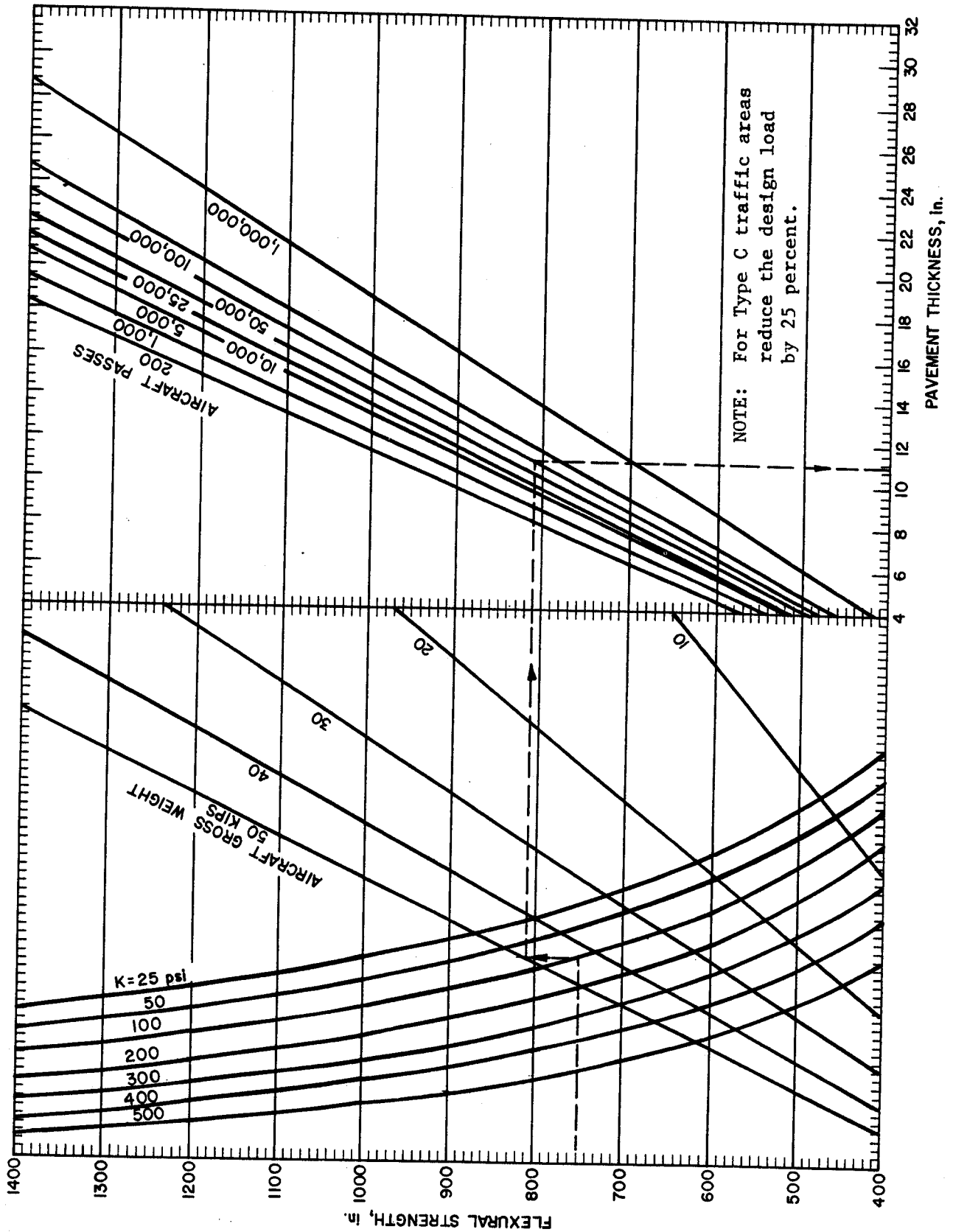

U. S. Army Corps of Engineers

FIGURE 2-2. JC PAVEMENT DESIGN CURVES FOR ARMY CLASS II PAVEMENTS

9 Apr 84

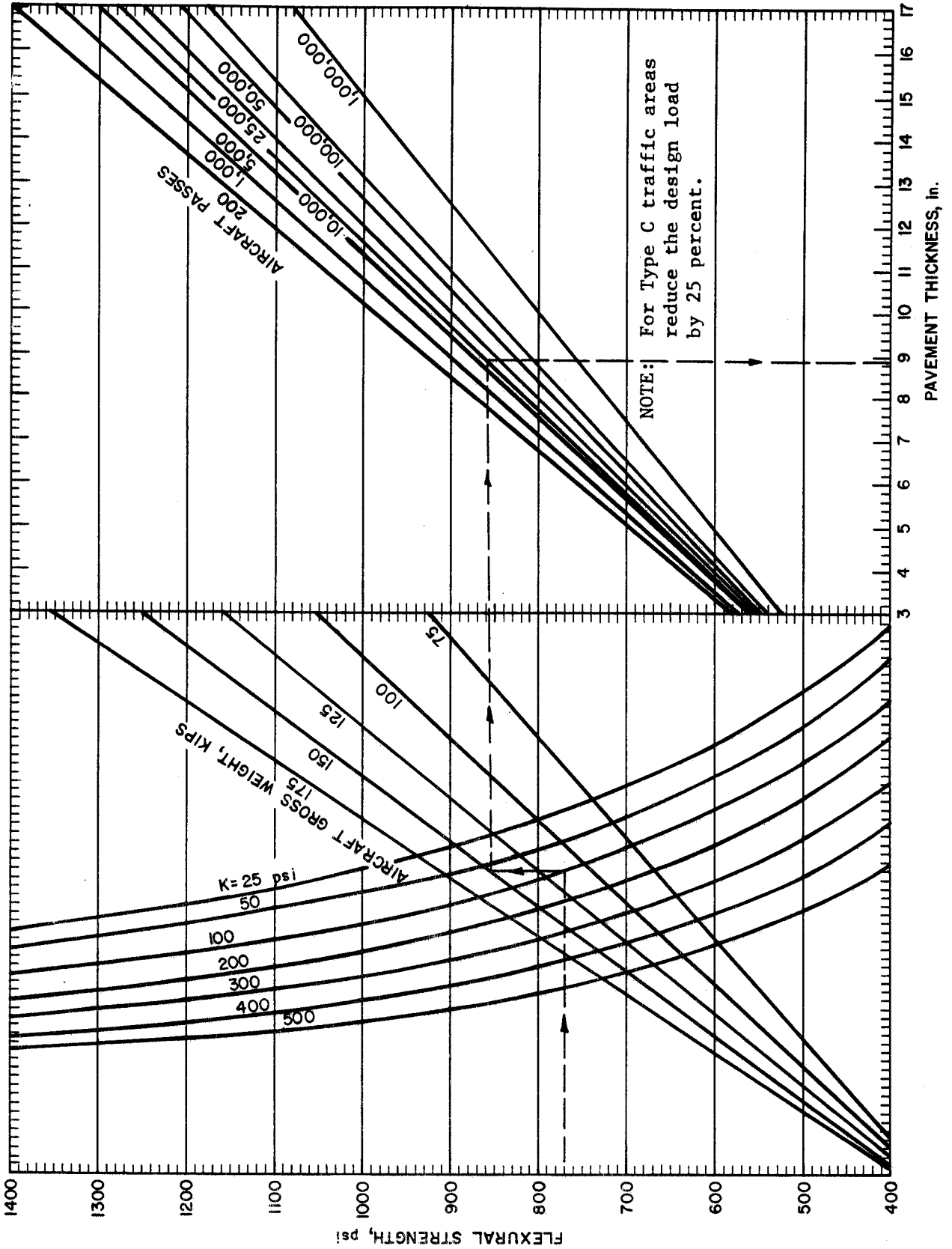

U. S. Army Corps of Engineers

FIGURE 2-3. JC PAVEMENT DESIGN CURVES FOR ARMY CLASS III PAVEMENTS

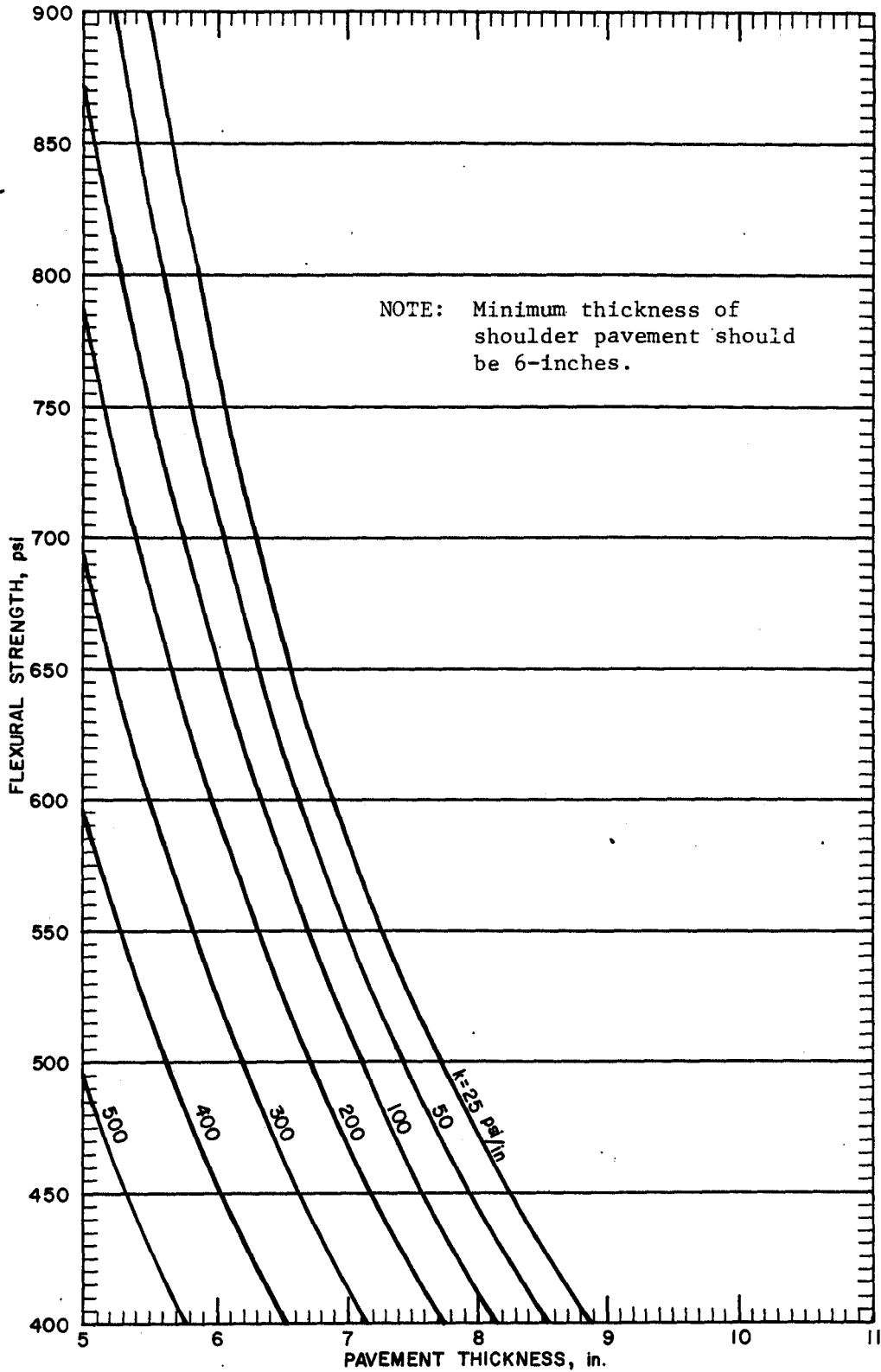

U. S. Army Corps of Engineers

FIGURE 2-4. PAVEMENT DESIGN CURVES FOR SHOULDERS



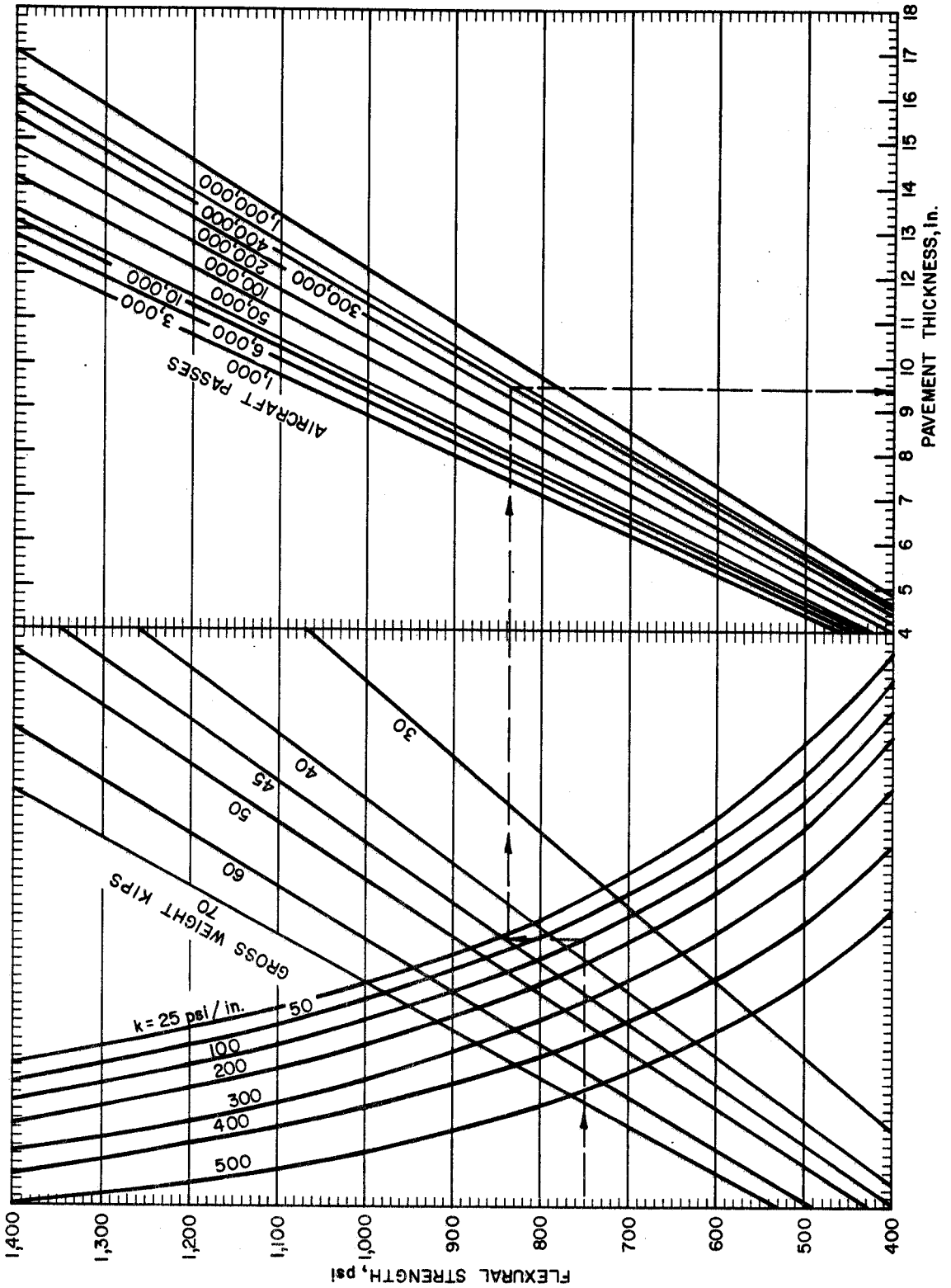

U. S. Army Corps of Engineers

FIGURE 2-5. JC PAVEMENT DESIGN CURVES FOR AIR FORCE LIGHT-LOAD PAVEMENTS

9 Apr 84

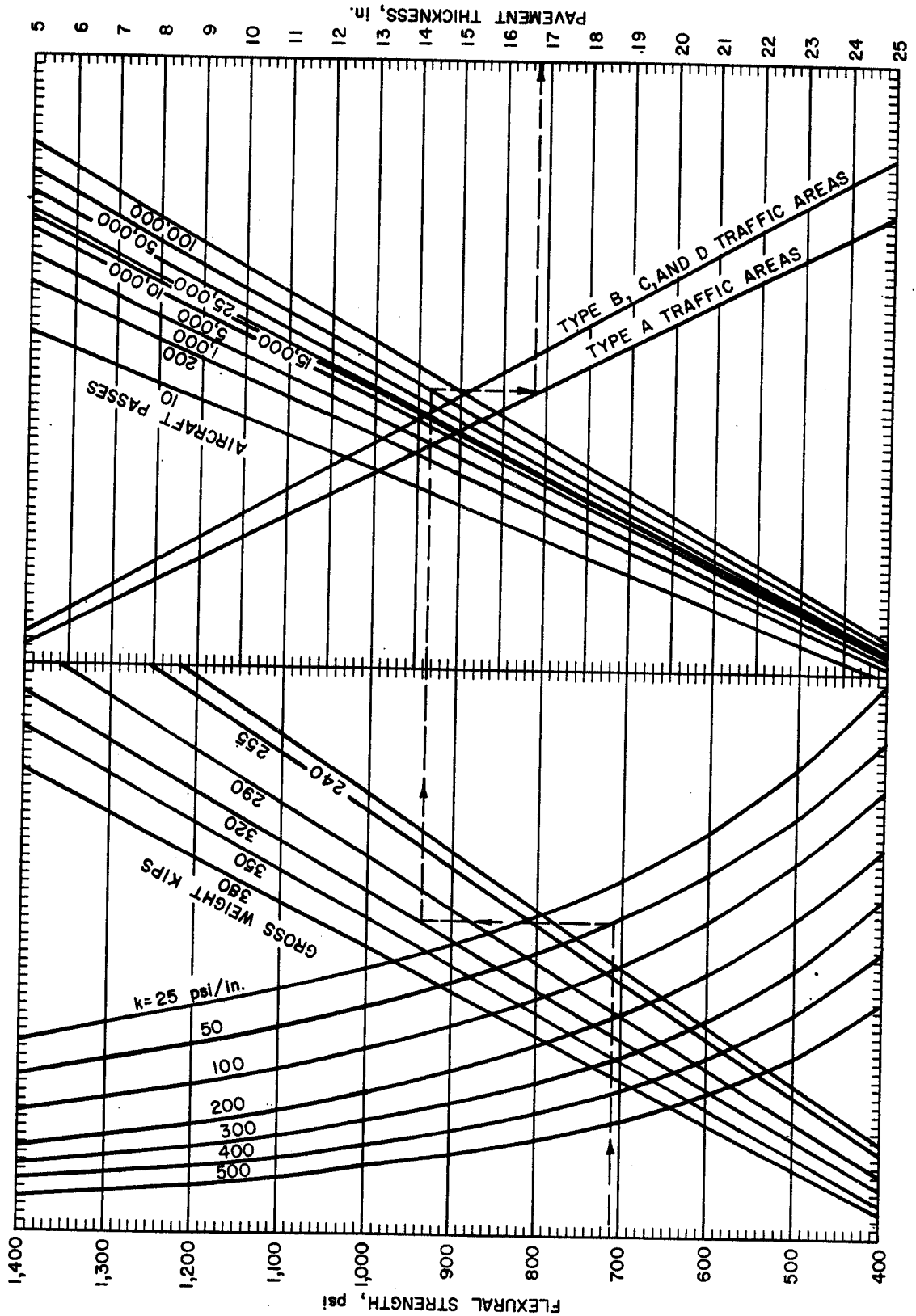

U. S. Army Corps of Engineers

FIGURE 2-6. JC PAVEMENT DESIGN CURVES FOR AIR FORCE MEDIUM-LOAD PAVEMENTS

9 Apr 84

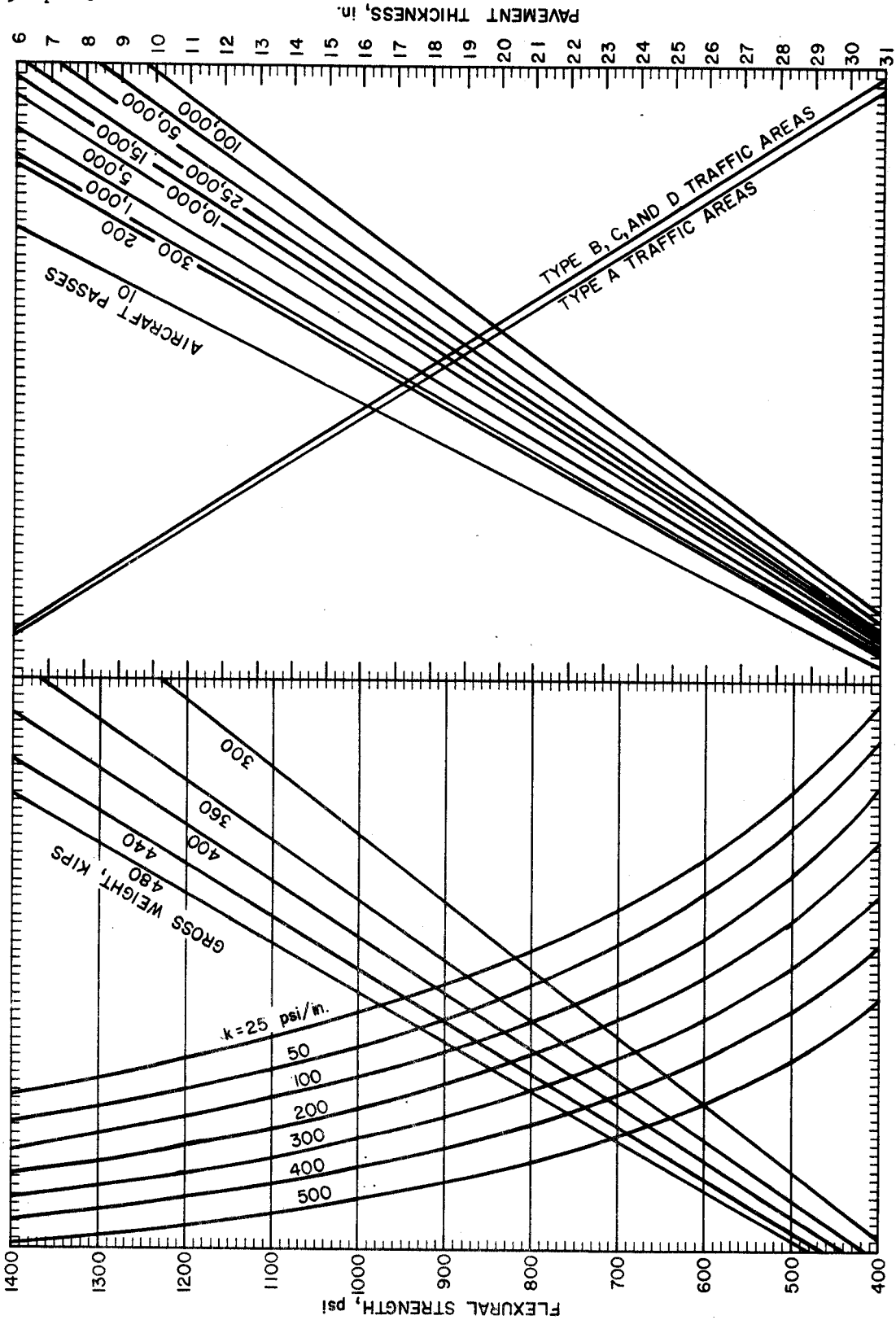

U. S. Army Corps of Engineers

FIGURE 2-7. JC PAVEMENT DESIGN CURVES FOR AIR FORCE HEAVY-LOAD PAVEMENTS

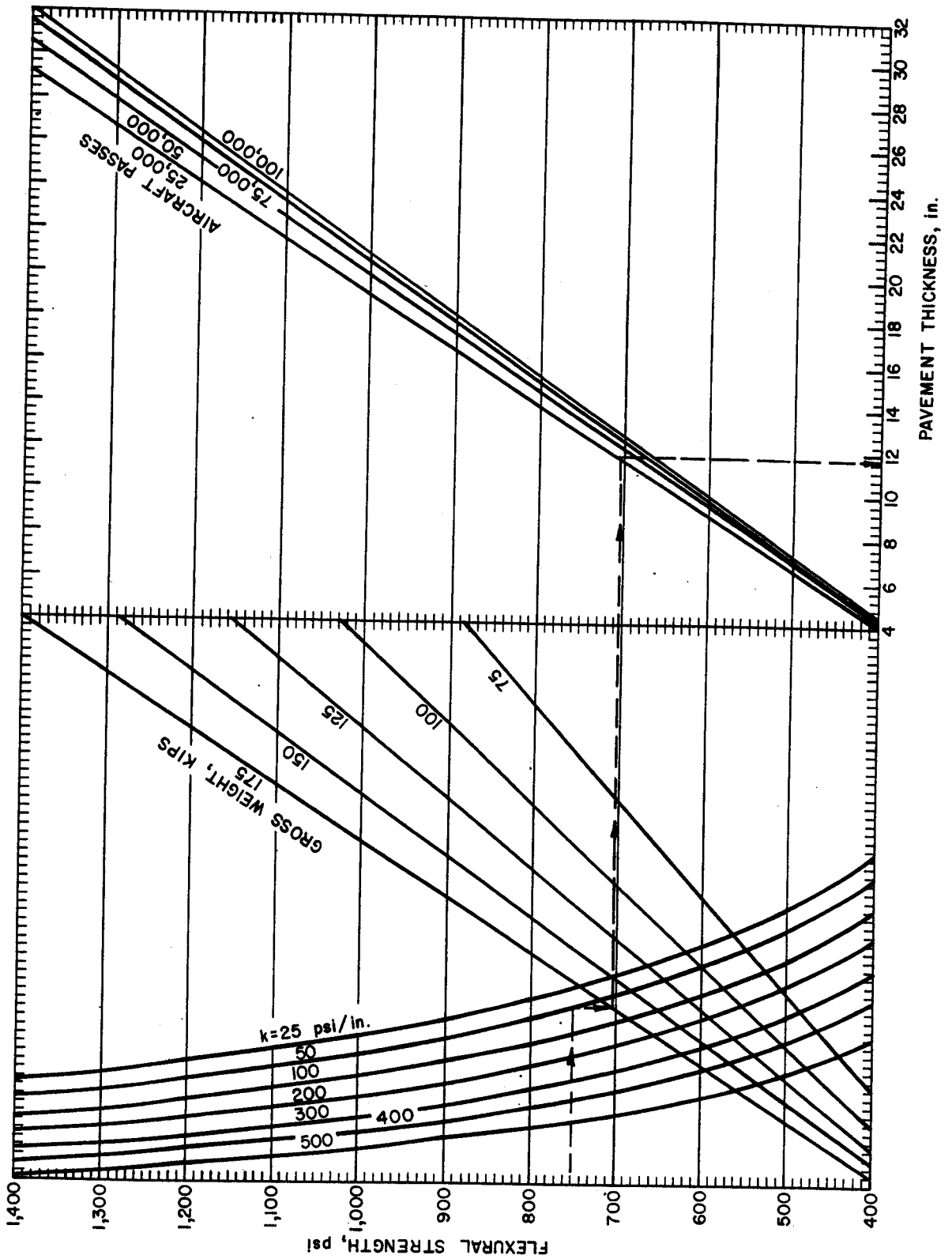

U. S. Army Corps of Engineers

FIGURE 2-8. JC PAVEMENT DESIGN CURVES FOR AIR FORCE SHORT FIELD PAVEMENTS

9 Apr 84

strips of concrete placed at different times. The three general types of joints, contraction, construction, and expansion, are shown in figures 2-9, 2-10, and 2-11, respectively. A typical jointing of the three types is illustrated in figure 2-12.

a. Contraction joints. Weakened-plane contraction joints are provided to control cracking in the concrete and to limit curling or warping stresses resulting from drying shrinkage and contraction and from temperature and moisture gradients in the pavement, respectively. Shrinkage and contraction of the concrete causes slight cracking and separation of the pavement at the weakened planes, which will provide some relief from tensile forces resulting from foundation restraint and compressive forces caused by subsequent expansion. Contraction joints will be required transversely and may be required longitudinally depending upon pavement thickness and spacing of construction joints.

(1) Width and depth of weakened plane groove. The width of the weakened plane groove will be a minimum of 1/8 inch and a maximum equal to the width of the sealant reservoir contained in paragraph (2) below. The depth of the weakened plane groove must be great enough to cause the concrete to crack under the tensile stresses resulting from the shrinkage and contraction of the concrete as it cures. This depth should be at least one fourth of the slab thickness for pavements 12 inches or less, 3 inches for pavements greater than 12 and less than 18 inches in thickness, and one sixth of the slab thickness for pavements greater than 18 inches in thickness. In no case will the depth of the groove be less than the maximum nominal size of aggregate used.

(2) Width and depth of sealant reservoir. The width and depth of the sealant reservoir for the weakened plane groove will conform to dimensions shown in figure 2-9. The dimensions of the sealant reservoir are critical to satisfactory performance of the joint sealing materials.

(3) Spacing of transverse contraction joints. Transverse contraction joints will be constructed across each paving lane, perpendicular to the center line, at intervals of not less than 12-1/2 feet and generally not more than 25 feet. The joint spacing will be uniform throughout any major paved area, and each joint will be straight and continuous from edge to edge of the paving lane and across all paving lanes for the full width of the paved area. Staggering of joints in adjacent paving lanes can lead to sympathetic cracking and will not be permitted unless reinforcement, as described in paragraph 3-2b, is used. The maximum spacing of transverse joints that will effectively control cracking will vary appreciably depending on pavement thickness, thermal coefficient and other characteristics of the aggregate and concrete, climatic conditions, and foundation restraint. It is impracticable to establish limits on joint spacing that are suitable for all conditions without making them unduly restrictive. The joint spacings in table 2-1 have given satisfactory

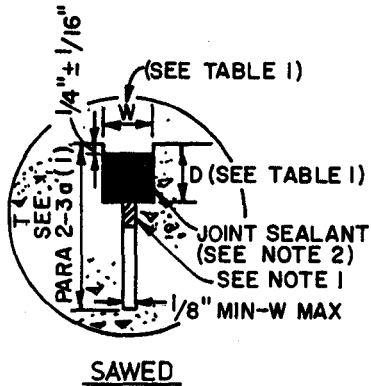
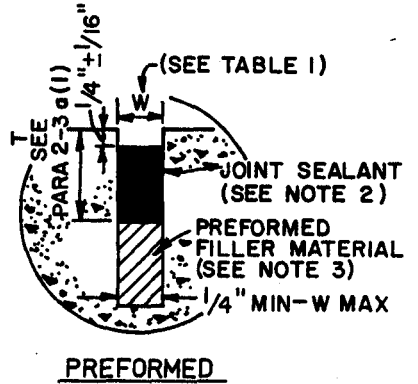

TABLE 1

| CONTRACTION JOINT SPACING, ft. | DIMENSIONS, in. |                  |
|--------------------------------|-----------------|------------------|
|                                | W               | D                |
| <20                            | $3/8 \pm 1/16$  | $3/4 \pm 1/16$   |
| 20-25                          | $1/2 \pm 1/16$  | $1 \pm 1/16$     |
| >25-50                         | $3/4 \pm 1/16$  | $1-1/4 \pm 1/16$ |
| >50-100                        | $1 \pm 1/16$    | $1-1/2 \pm 1/16$ |



NOTE 1: Nonabsorptive material required to prevent joint sealant from flowing into sawcut and to separate noncompatible materials.

2: Joint sealant may be pourable or preformed type (see para 2-3e).

3: Preformed filler may be fiberboard or other approved material which can be sawed or which can have a section removed to form a sealant reservoir.

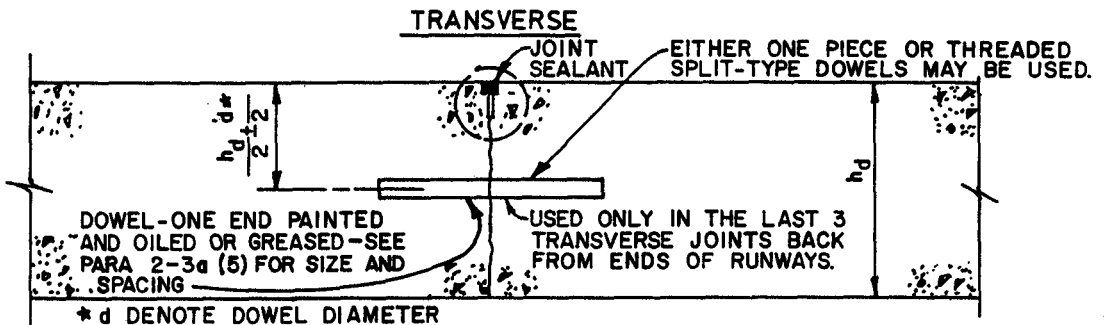
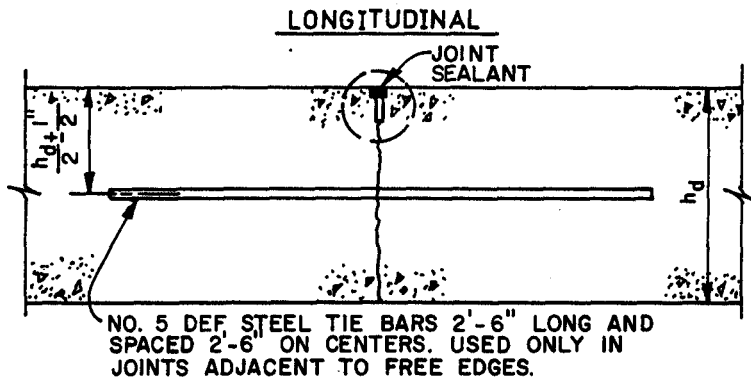

U. S. Army Corps of Engineers

FIGURE 2-9. CONTRACTION JOINTS FOR JC PAVEMENTS

**KEYED LONGITUDINAL**

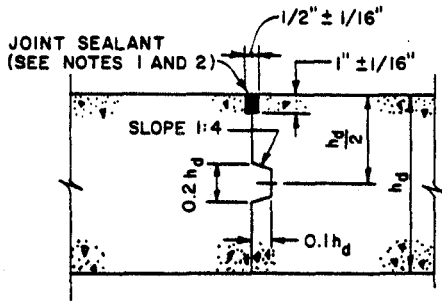

NOTE: A tolerance of plus or minus 1/16 inch may be allowed for key dimensions and location.

**KEYED AND TIED LONGITUDINAL**

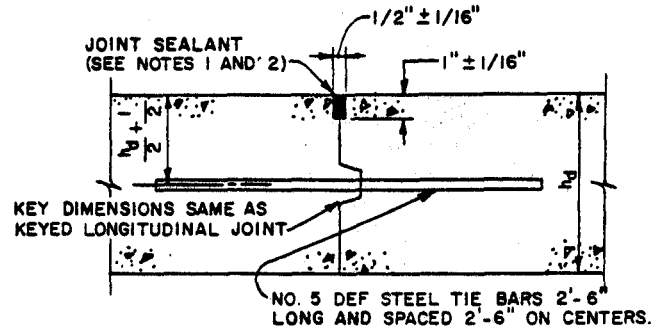

**THICKENED EDGE LONGITUDINAL**

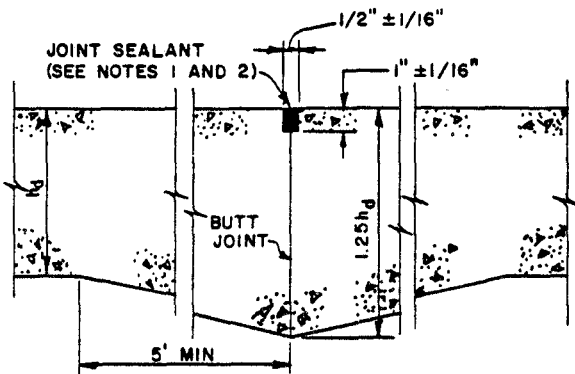

**DOWELED TRANSVERSE OR LONGITUDINAL**

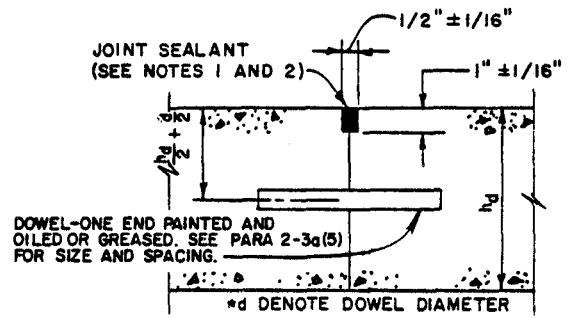

NOTE: Either one piece or threaded split type dowel may be used.

**KEYED THICKENED EDGE LONGITUDINAL**

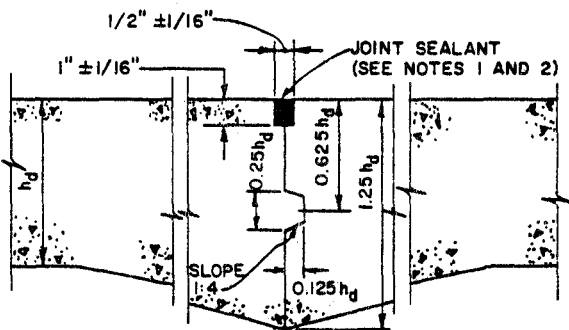

**SPECIAL JOINT BETWEEN NEW & EXISTING PAVEMENT TRANSVERSE OR LONGITUDINAL (SEE PARA 2-4c)**

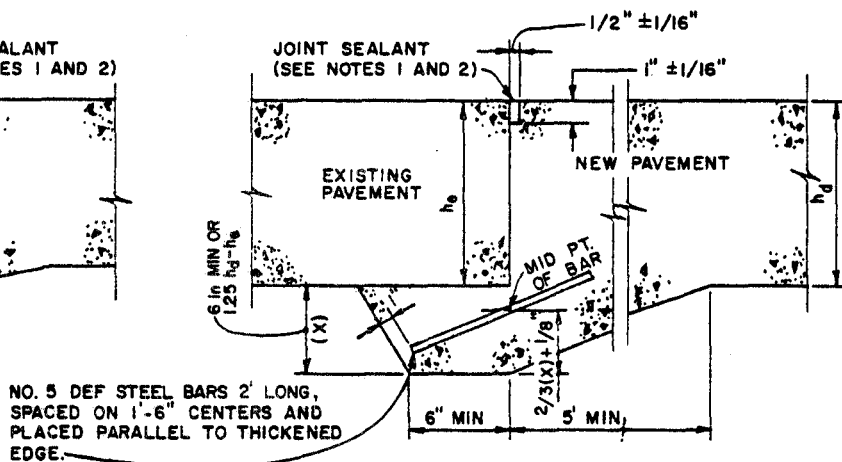

NO. 5 DEF STEEL BARS 2' LONG, SPACED ON 1'-6" CENTERS AND PLACED PARALLEL TO THICKENED EDGE.

- NOTE: 1. Top of joint sealant will be 1/4 inch plus or minus 1/16 inch below top of pavement.  
2. Joint sealant may be pourable or preformed type (see para 2-3e).

U. S. Army Corps of Engineers

FIGURE 2-10. CONSTRUCTION JOINTS FOR JC PAVEMENTS

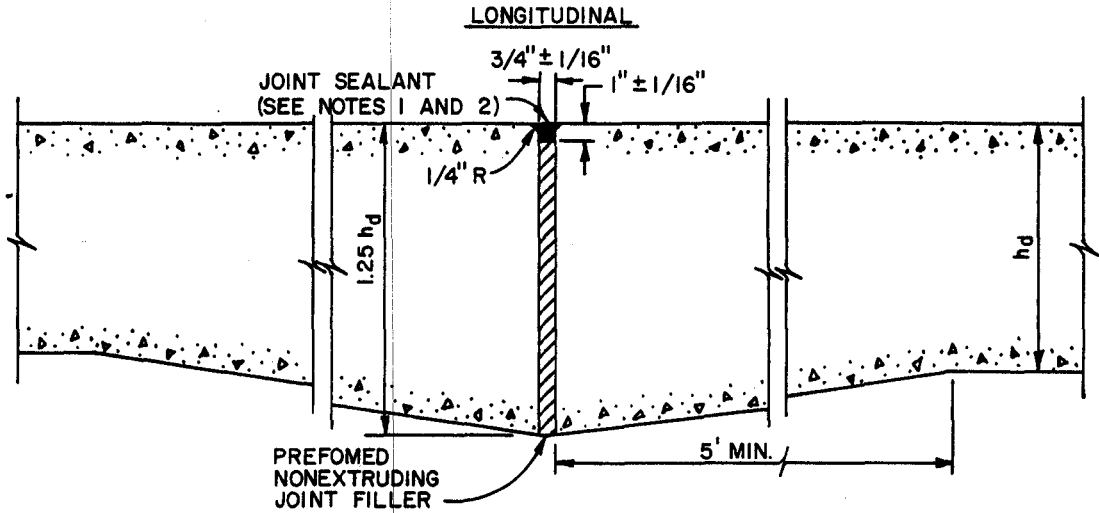

- NOTES:
1. Top of joint sealant will be 1/4 inch plus or minus 1/16 inch below top of pavement.
  2. Joint sealant may be pourable or preformed type (See para 2-3e).
  3. Either one piece or threaded split type dowels may be used.

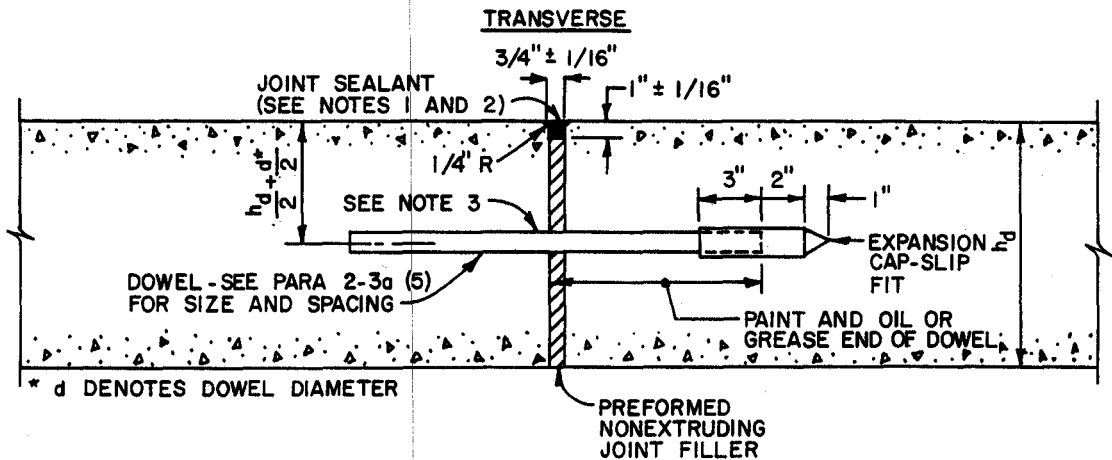

U. S. Army Corps of Engineers

FIGURE 2-11. EXPANSION JOINTS FOR JC PAVEMENTS



9 Apr 84

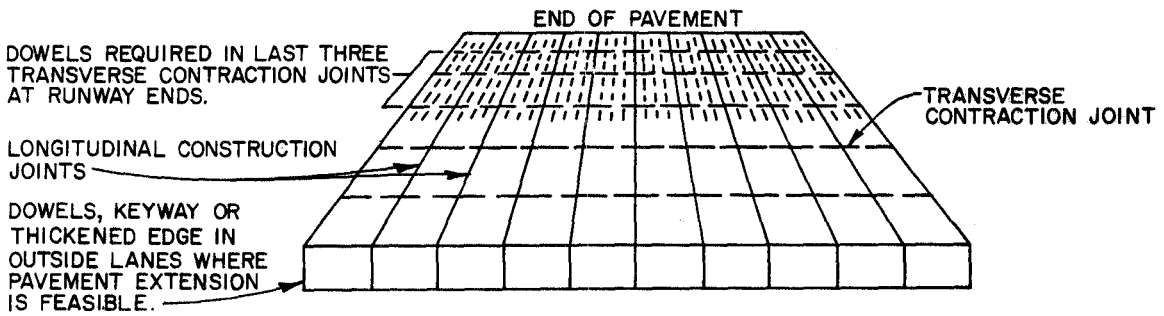
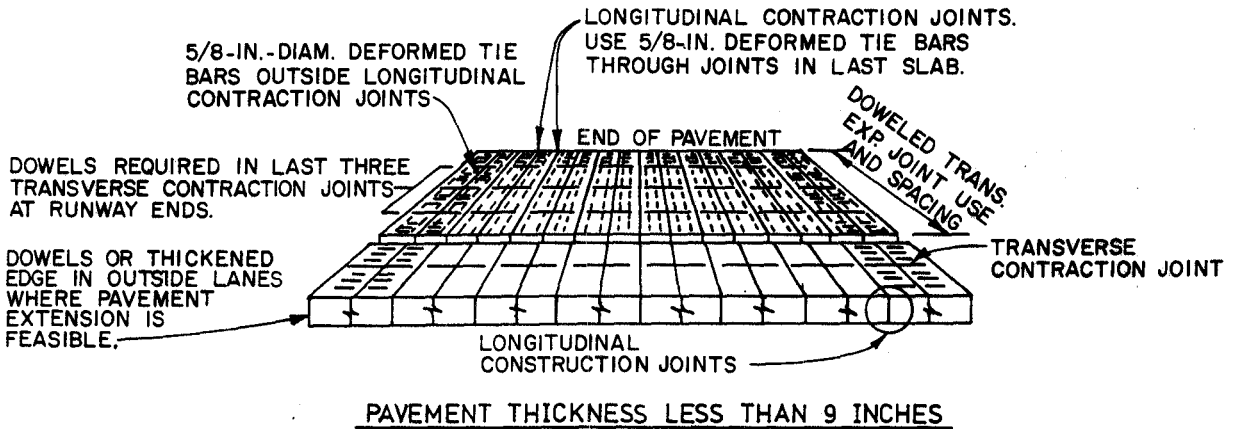

Note: If lanes greater than 20 feet wide are used, longitudinal contraction joints must be placed in the center of each lane. Tie bars will be used in outside longitudinal contraction joints.

PAVEMENT THICKNESS, 9 TO 12 INCHES

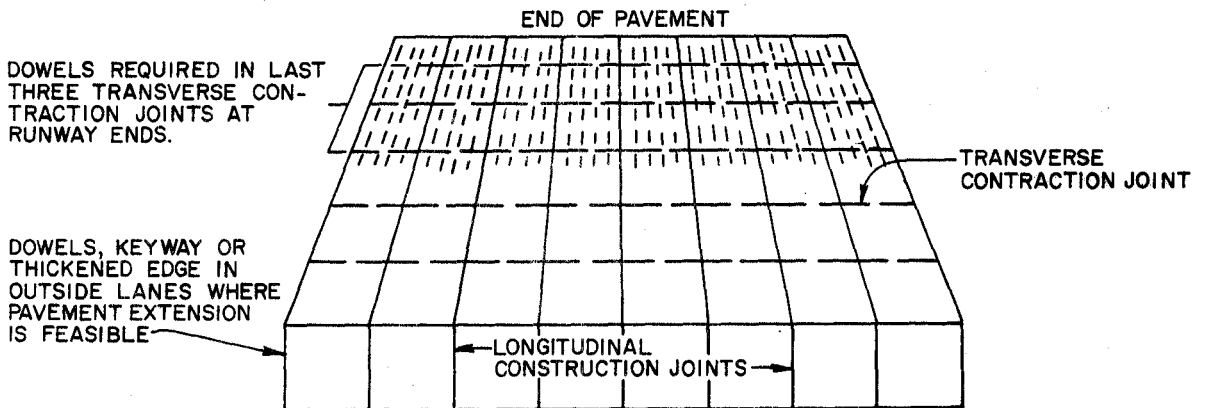

Note: If paving lanes greater than 25 feet are used, longitudinal contraction joints must be placed in center of each lane.

PAVEMENT THICKNESS GREATER THAN 12 INCHES

U. S. Army Corps of Engineers

FIGURE 2-12. TYPICAL JOINTING

9 Apr 84

control of transverse cracking in most instances and may be used as a guide, subject to modification based on available information regarding the performance of existing pavements in the vicinity or unusual properties of the concrete. For best pavement performance, the number of joints should be kept to a minimum by using the greatest joint spacing that will satisfactorily control cracking. Experience has shown, however, that oblong slabs, especially in thin pavements, tend to crack into smaller slabs of nearly equal dimensions under traffic. Therefore, it is desirable, insofar as practicable, to keep the length and width dimensions as nearly equal as possible. In no case should the length dimension (in the direction of paving) exceed the width dimension more than 25 percent. Under certain climatic conditions, joint spacings different from those in table 2-1 may be satisfactory.

Table 2-1. Recommended Spacing of Transverse  
Contraction Joints

| <u>Pavement Thickness, inches</u> | <u>Spacing, feet</u> |
|-----------------------------------|----------------------|
| Less than 9                       | 12-1/2 to 15         |
| 9 to 12                           | 15 to 20             |
| Over 12                           | 20 to 25             |

(4) Spacing of longitudinal contraction joints. Contraction joints will be placed along the center line of paving lanes that have a width greater than the indicated maximum spacing of transverse contraction joints in table 2-1. Contraction joints may also be required in the longitudinal direction for overlays, regardless of overlay thickness, to match joints existing in the base pavement unless a bond-breaking medium is used between the overlay and base pavement or the overlay pavement is reinforced (para 3-3b(2)).

(5) Doweled and tied contraction joints. Dowels will be required in the last three transverse contraction joints back from the ends of all runways to provide positive load transfer in case of excessive joint opening due to progressive growth of the pavement. Similar dowel requirements may be included in the transverse contraction joints at the ends of other long paved areas, such as taxiways or aprons where local experience indicates that excessive joint opening may occur. In rigid overlays in Type A traffic areas, longitudinal contraction joints that would coincide with an expansion joint in the base pavement will be doweled. Dowel size and spacing will be as specified in table 2-2. Deformed tie bars, 5/8-inch diameter by 30 inches long, spaced on 30-inch centers, will be required in longitudinal contraction joints that fall 15 feet or less from the free edge of paved areas greater than 100 feet in width to prevent cumulative opening of these joints.

b. Construction joints. Construction joints may be required in both the longitudinal and transverse directions. Longitudinal

Table 2-2. Dowel Size and Spacing for Construction,  
Contraction, and Expansion Joints

| <u>Pavement Thickness, inches</u> | <u>Minimum Dowel Length, inches</u> | <u>Maximum Dowel Spacing, inches</u> | <u>Dowel Diameter and Type</u>                                |
|-----------------------------------|-------------------------------------|--------------------------------------|---|
| Less than 8                       | 16                                  | 12                                   | 3/4-inch bar  |
| 8 to and including 11.5           | 16                                  | 12                                   | 1-inch bar  |
| 12 to and including 15.5          | 20                                  | 15                                   | 1- to 1-1/4-inch bar, or 1-inch extra-strength pipe           |
| 16 to and including 20.5          | 20                                  | 18                                   | 1- to 1-1/2-inch bar, or 1- to 1-1/2-inch extra-strength pipe |
| 21 to and including 25.5          | 24                                  | 18                                   | 2-inch bar, or 2-inch extra-strength pipe                     |
| Over 26                           | 30                                  | 18                                   | 3-inch bar, or 3-inch extra strength pipe                     |

U. S. Army Corps of Engineers

9 Apr 84

construction joints, generally spaced 20 to 25 feet apart but may reach 50 feet apart depending on construction equipment capability, will be required to separate successively placed paving lanes. Transverse construction joints will be installed when it is necessary to stop concrete placement within a paving lane for a sufficient time for the concrete to start to set. All transverse construction joints will be located in place of other regularly spaced transverse joints (contraction or expansion types). There are several types of construction joints available for use as shown in figure 2-10. These joints are described in paragraphs (1), (2), and (3) below. The selection of the type of construction joint will depend on such factors as the concrete placement procedure (formed or slipformed), pavement design classes, and foundation conditions.

(1) Doweled butt joint. The doweled butt joint is considered to be the best joint insofar as providing load transfer and maintaining slab alignment is concerned. Therefore, it is the desirable joint for the most adverse conditions, such as heavy loading, high traffic intensity, and lower strength foundations. However, because the alignment and placement of the dowel bars are critical to satisfactory performance, this type of joint is difficult to construct, especially for slipformed concrete. The doweled butt joint is required for all transverse construction joints.

(2) Thickened-edge joint. Thickened-edge-type joints may be used in lieu of other types of joints employing load transfer devices. The thickened-edge joint is constructed by increasing the thickness of the concrete at the edge to 125 percent of the thickness determined from paragraph 2-2. The thickness is then reduced by tapering from the free-edge thickness to the design thickness at a distance 5 feet from the longitudinal edge. The thickened-edge butt joint is considered adequate for the load-induced concrete stresses. However, the inclusion of a key in the thickened-edge joint provides some degree of load transfer in the joint and helps maintain slab alignment; although not required, it is recommended for pavement constructed on low- or medium-strength foundations. The thickened-edge joint may be used at free edges of paved areas to accommodate future expansion of the facility or where aircraft wheel loadings may track the edge of the pavement.

(3) Keyed joint. The keyed joint is the most economical method, from a construction standpoint, of providing load transfer in the joint. It has been demonstrated that the key or keyway can be satisfactorily constructed using either formed or slipformed methods. Experience has demonstrated that the required dimensions of the joint can best be maintained by forming or slipforming the keyway rather than the key. The dimensions and location of the joint (fig 2-10) are critical to its performance. Deviations exceeding the stated tolerances can result in failure in the joint. Experience has shown that the keyed joint may not perform adequately for high-volume medium

9 Apr 84

and heavy loads in pavements constructed on low- and medium-strength foundations. Tie bars in the keyed joint will limit opening of the joint and provide some shear transfer that will improve the performance of the keyed joints. However, tied joints in pavement widths of more than 75 feet can result in excessive stresses and cracking in the concrete during contraction.

c. Expansion joints. Expansion joints will be used at all intersections of pavements with structures and may be required within the pavement features. A special feature requiring expansion joints is a nonperpendicular pavement intersection. The two types of expansion joints are the thickened-edge and the doweled type (fig 2-11), both of which will be provided with a nonextruding-type filler material. The type and thickness of filler material and the manner of its installation will depend upon the particular case. Usually a preformed material of 3/4-inch thickness will be adequate; however, in some instances a greater thickness of filler material may be required. Where large expansions may have a detrimental effect on adjoining structures, such as at the juncture of rigid and flexible pavements, expansion joints in successive transverse joints back from the juncture should be considered. The depth, length, and position of each expansion joint will be sufficient to form a complete and uniform separation between the pavements or between the pavement and the structure concerned.

(1) Between pavement and structures. Expansion joints will be installed to surround, or to separate from the pavement, any structures that project through, into, or against the pavements, such as at the approaches to buildings or around drainage inlets and hydrant refueling outlets. The thickened-edge-type expansion joint will normally be best suited for these places.

(2) Within pavements. Expansion joints within pavements are difficult to construct and maintain, and they often contribute to pavement failures. Their use will be kept to the absolute minimum necessary to prevent excessive stresses in the pavement from expansion of the concrete or to avoid distortion of a pavement feature through the expansion of an adjoining pavement. The determination of the need for and spacing of expansion joints will be based upon: pavement thickness, thermal properties of the concrete, prevailing temperatures in the area, temperatures during the construction period, and the experience with concrete pavements in the area. Unless needed to protect abutting structures, expansion joints will be omitted in all pavements 10 inches or more in thickness and also in pavements less than 10 inches in thickness when the concrete is placed during warm weather, since the initial volume of the concrete on hardening will be at or near the maximum. However, for concrete placed during cold weather, expansion joints may be used in pavements less than 10 inches thick.

9 Apr 84

(a) Longitudinal expansion joints within pavements will be of the thickened-edge type (fig 2-11). Dowels are not recommended in longitudinal expansion joints because differential expansion and contraction parallel with the joints may develop undesirable localized strains and possibly failure of the concrete, especially near the corners of slabs at transverse joints.

(b) Transverse expansion joints within pavements will be the doweled type (fig 2-11). There may be instances when it will be desirable to allow some slippage in the transverse joints, such as at the angular intersection of pavements to prevent the expansion of one pavement from distorting the other. In these instances, the design of the transverse expansion joints will be similar to the thickened-edge slip joints (para 2-4b). When a thickened-edge joint (slip joint) is used at a free edge not perpendicular to a paving lane, a transverse expansion joint will be provided 75 to 100 feet back from the free edge.

(c) Dowels. The important functions of dowels or any other load-transfer device in concrete pavements are: to help maintain the alinement of adjoining slabs and to limit or reduce stresses resulting from loads on the pavement. Different sizes of dowels will be specified for different thicknesses of pavements (table 2-2). When extra-strength pipe is used for dowels, the pipe will be filled with either a stiff mixture of sand-asphalt or portland cement mortar, or the ends of the pipe will be plugged. If the ends of the pipe are plugged, the plug must fit inside the pipe and be cut off flush with the end of the pipe so that there will be no protruding material to bond with the concrete and prevent free movement of the dowel. Figures 2-9 through 2-11 show the dowel placement. All dowels will be straight, smooth, and free from burrs at the ends. One end of the dowel will be painted and oiled or greased to prevent bonding with the concrete. Dowels used at expansion joints will be capped at one end, in addition to painting and oiling or greasing, to permit further penetration of the dowels into the concrete when the joints close.

d. Special provisions for slipform paving. Provisions must be made for slipform pavers when there is a change in longitudinal joint configuration. The thickness may be varied without stopping the paving train, but the joint configuration cannot be varied without modifying the side forms, which will normally require stopping the paver and installing a header. The following requirements shall apply:

(1) The header may be set on either side of the transition slab with the transverse construction joint doweled as required. The dowel size and location in the transverse construction joint should be commensurate with the thickness of the pavement at the header.

9 Apr 84

(2) When there is a transition between a doweled longitudinal construction joint and a keyed longitudinal construction joint, the longitudinal construction joint in the transition slab may be either keyed or doweled. The size and location of the dowels or keys in the transition slabs should be the same as those in the pavement with the doweled or keyed joint, respectively.

(3) When there is a transition between two keyed joints with different dimensions, the size and location of the key in the transition slab should be based on the thickness of the thinner pavement.

e. Joint sealing. All joints will be sealed with a suitable sealant to prevent infiltration of surface water and solid substances. JFR sealants will be used in the joints or aprons, warm-up holding pads, hardstands, washracks, and other paved areas where fuel may be spilled during the operation, parking, maintenance, and servicing of aircraft. In addition, heat-resistant JFR joint sealant materials will be used for runway ends and other areas where the sealant material may be subject to prolonged heat and blast of jet aircraft engines. Non-JFR sealants will be used in joints of all other airfield pavements. An optimal sealant, meeting both the heat- and blast-resistant JFR and non-JFR sealant requirements, is a preformed polychloroprene elastomeric material. Preformed sealants must have an uncompressed width of not less than twice the width of the joint sealant reservoir. The selection of a pourable or preformed sealant should be based upon the economics involved. Compression-type preformed sealants are recommended when the joint spacings exceed 25 feet and are required when joint spacings exceed 50 feet.

2-4. Special joints and junctures. Situations will develop where special joints or variations of the more standard type joints will be needed to accommodate the movements that will occur and to provide a satisfactory operational surface. Some of these special joints or junctures are as follows:

a. Juncture between rigid and flexible pavements. Experience has shown that objectionable roughness often develops at the juncture of a rigid and flexible pavement under aircraft traffic. This roughness generally takes the form of subsidence or shoving. In order to minimize the roughness, a juncture design has been prepared as illustrated in figure 2-13. The junctures are intended for critical traffic areas or in areas where slight deviations from the design grade are objectionable. Specifically, the junctures should be incorporated where rigid pavement joins flexible pavement at all transverse junctures in runway and taxiways. These special junctures will not be required between aprons or in junctures to blast pads, overruns, and stabilized shoulders. The buried rigid-slab-type juncture as detailed in figure 2-13 is provided for all pavement designs. No joints will be required in the buried rigid slab. Provide the second expansion joint

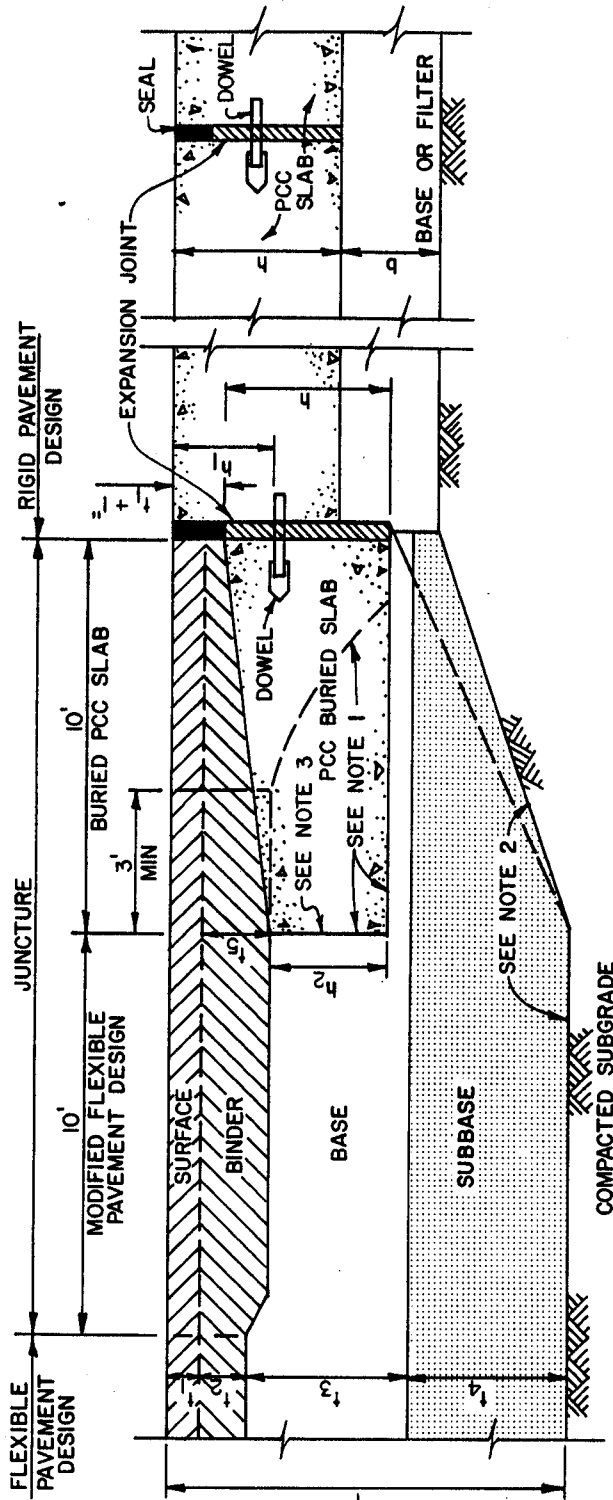

**LEGEND TO THICKNESS**

| SYMBOL         | HEAVY AND MEDIUM LOAD DESIGN                            | LIGHT AND SHORTFIELD LOAD DESIGN                        |
|----------------|---|---|
| h              | Design thickness of PCC                                 | Design thickness of PCC                                 |
| h <sub>1</sub> | $\frac{h + t_1 + 1}{2}$                                 | $\frac{h + t_1 + 1}{2}$                                 |
| h <sub>2</sub> | h - t <sub>5</sub> + 1" but not less than 6"            | h - t <sub>5</sub> + 1 but not less than 4"             |
| b              | Thickness of base or filter                             | Thickness of base or filter                             |
| t              | Design thickness of flexible pavement                   | Design thickness of flexible pavement                   |
| t <sub>1</sub> | Design thickness of surface course                      | Design thickness of surface course                      |
| t <sub>2</sub> | Design thickness of binder course                       | Design thickness binder course                          |
| t <sub>3</sub> | Design thickness of base course                         | Design thickness of base course                         |
| t <sub>4</sub> | Design thickness of subbase course                      | Design thickness of subbase course                      |
| t <sub>5</sub> | h - h <sub>2</sub> + 1 but not less than t <sub>2</sub> | h - h <sub>2</sub> + 1 but not less than t <sub>2</sub> |

- NOTES:**
1. Compact flexible pavement to dotted line. Cut out to solid line not disturbing the materials outside limits of buried slab.
  2. Excavate and compact subgrade to dotted line if a base or filter is not used beneath PCC. Excavate and compact subgrade to solid line when base or filter course is used beneath PCC.
  3. Place PCC buried slab directly against cut back base course. No form will be used.
  4. Top lift of binder to be placed and rolled transversely. Surface course placed and rolled longitudinally stopping rollers on rigid pavement.

U. S. Army Corps of Engineers

FIGURE 2-13. DESIGN OF RIGID-FLEXIBLE PAVEMENT JUNCTURE



9 Apr 84

between the rigid pavements when the rigid pavement is 1,600 feet in length or longer; install the second expansion joint in the last joint of the rigid pavement. When joining a new rigid pavement to an existing flexible pavement, cut the existing flexible pavement back to the dimension for "buried PCC slab" only. The portion labeled "modified flexible pavement design" will not be incorporated because of the possibility of destroying the existing density of the base course materials. When the juncture is installed during the construction of a new flexible pavement joining an existing rigid pavement, the existing rigid pavement will be drilled and doweled for the expansion joint. The dowels will be bonded in the existing rigid pavement with epoxy grout.

b. Slip-type joints. At the juncture of two pavement facilities, such as a taxiway and runway, expansion and contraction of the concrete may result in movements that occur in different directions. Such movements may create detrimental stresses within the concrete unless a provision is made to allow the movements to occur. At such junctures, a thickened-edge slip joint should be used to permit the horizontal slippage to occur. The design of the thickened-edge slip joint will be similar to the thickened-edge construction joint (fig 2-10). The bond-breaking medium will be either a heavy coating of bituminous material not less than 1/16 inch in thickness when joints match or a normal nonextruding-type expansion joint material not less than 1/4 inch in thickness when joints do not match. The 1/16-inch bituminous coating may be either a low penetration (60-70 grade asphalt) or a clay-type asphalt-base emulsion similar to that used for roof coating and will be applied to the face of the joint by hand brushing or spraying.

c. Special joint between new and existing pavements. A special thickened-edge joint design (fig 2-10) will be used at the juncture of new and existing pavements for the following conditions:

- When load-transfer devices (keyways or dowels) or a thickened edge was not provided at the free edge of the existing pavement.
- When load-transfer devices or a thickened edge was provided at the free edge of the existing pavement but neither met the design requirements for the new pavement.
- For transverse contraction joints, when removing and replacing slabs in an existing pavement.
- For longitudinal construction joints, when removing and replacing slabs in an existing pavement if the existing load-transfer devices are damaged during the pavement removal.
- Any other location where it is necessary to provide load transfer for the existing pavements.

9 Apr 84

The special joint design may not be required if a new pavement joins an existing pavement that is grossly inadequate to carry the design load of the new pavement or if the existing pavement is in poor structural condition. If the existing pavement can carry a load that is 75 percent or less of the new pavement design load, special efforts to provide edge support for the existing pavement may be omitted; however, if omitted, accelerated failures in the existing pavement may be experienced. Any load-transfer devices in the existing pavement should be used at the juncture to provide as much support as possible to the existing pavement. The new pavement will simply be designed with a thickened edge at the juncture. Drilling and grouting dowels in the existing pavement for edge support may be considered as an alternative to the special joint; however, a thickened-edge design will be used for the new pavement at the juncture.

## CHAPTER 3

### JOINTED REINFORCED CONCRETE (JRC) PAVEMENT DESIGN

3-1. Uses. JRC pavement may be used as slabs on grade or as overlay pavement for any traffic area of the airfield. Reinforcement may be used to reduce the required thickness and permit greater spacing between joints. Its selection should be based upon the materials available and time element involved. In certain instances, reinforcement will be required to control cracking that may occur in the JC pavements without any reduction in thickness requirements.

3-2. Reduced thickness design. The thickness of JRC pavement can be less than the thickness of JC pavements. The design procedure presented herein yields the thickness of JRC pavement and the percentage of steel reinforcement  $S$  required to provide the same performance as a predetermined thickness of JC pavement constructed on the same foundation condition. The greatest use of reinforcement to reduce the required JC pavement thickness will probably be to provide a uniform thickness for the various traffic areas and to meet surface grade requirements. This is especially true for rigid overlays where it is necessary to provide different thicknesses for the various types of traffic areas or different structural conditions of the base pavement. Since these changes in thickness cannot be made at the surface, reinforcement can be used to reduce the required thickness and thereby obviate the necessity for removal and replacement of pavements or overdesigns. There are other instances in which reinforcement to reduce the pavement thickness may be warranted and must be regarded. The design procedure consists of determining the percentage of steel required, the thickness of the JRC pavement, and the maximum allowable length of slabs.

a. Determination of required percent steel and required thickness of JRC pavement. It is first necessary to determine the required thickness  $h_{dc}$  of JC pavement using the design loading and physical properties of the pavement and foundation (chap 2). When the JRC pavement is to be used on nonstabilized bases or subgrades, the procedure outlined in paragraph 2-2a will be used to determine  $h_{dc}$ ; whereas, when the JRC pavement is to be used on stabilized layers of material, the procedure outlined in 2-3b will be used. The thickness,  $h_{dc}$  or  $h_{doc}$ , is then used to enter the nomograph (fig 3-1) to determine the required percent steel,  $S$ , and required thickness  $h_{dr}$  or  $h_{dor}$  of JRC pavement. Since the thickness  $h_{dr}$  and  $S$  are interrelated, it will be necessary to establish a desired value of one and determine the other. The resulting values of  $h_{dr}$  and  $S$  will represent a JRC pavement that will provide the same performance as the required thickness of concrete pavement,  $h_{dc}$  or  $h_{doc}$ . In all cases, when the required thickness  $h_{dc}$  is reduced by the addition of reinforcing steel, the design percentage of steel will be placed in each of two directions (transverse and longitudinal) in the slab. For construction purposes,

$A_s$  = Cross-sectional area of steel in square inch per foot of pavement

$L$  = Max allowable length of JRC pavement slab

$f_s$  = Yield strength of reinforcing steel in psi

$S$  = Percent of reinforcing steel

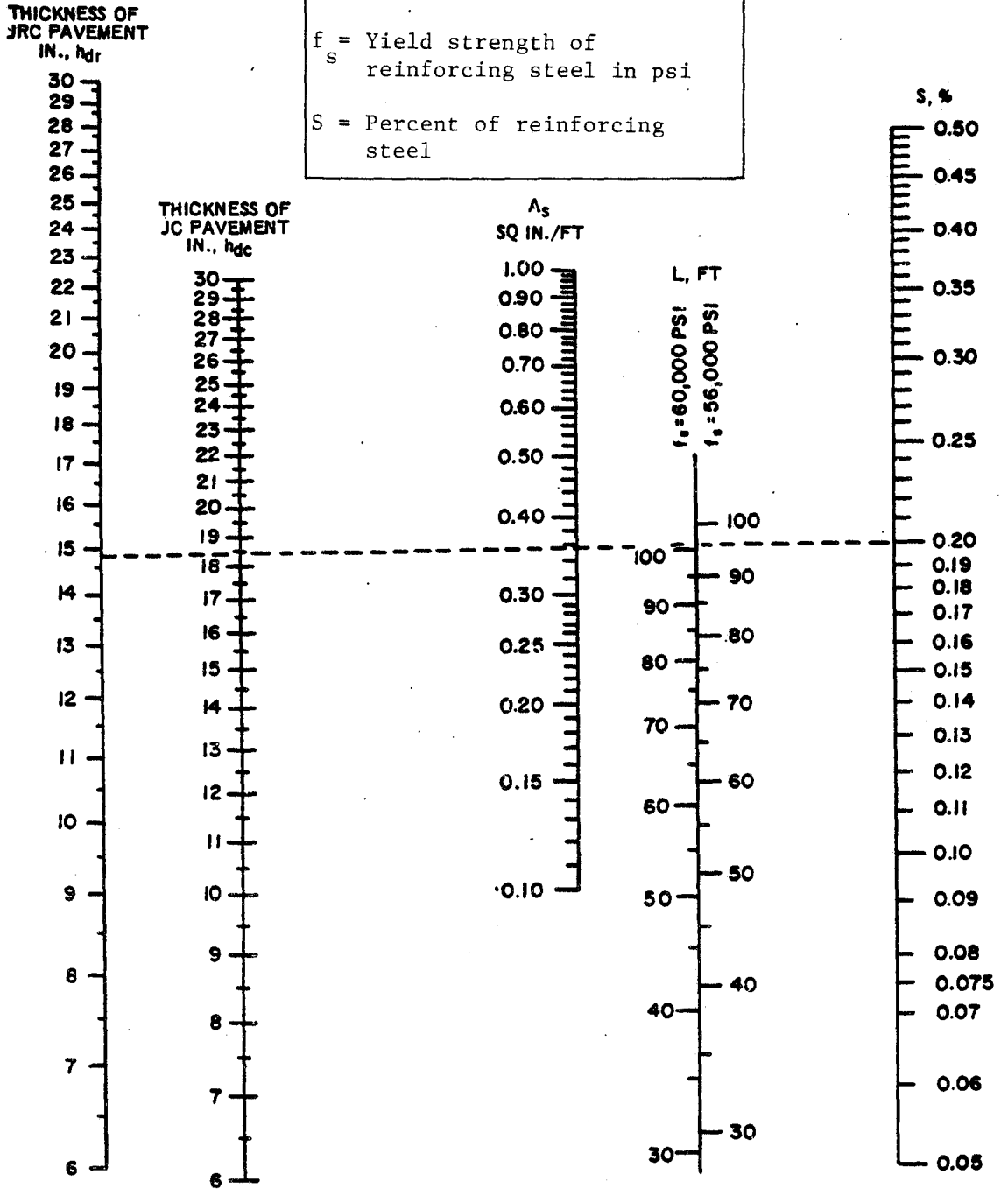

U. S. Army Corps of Engineers

FIGURE 3-1. JOINTED REINFORCED CONCRETE PAVEMENT DESIGN

9 Apr 84

the required thickness  $h_{dr}$  must be rounded to the nearest full- or half-inch increment. When the indicated thickness is midway between full- and half-inch or half and full increments, the thickness will be rounded upward.

b. Determination of maximum JRC pavement slab size. The maximum length or width of JRC pavement slab is dependent largely upon the resistance to movement of the slab on the underlying material and the yield strength of the reinforcing steel. The latter factor can be easily determined; however, very little reliable information is available regarding the sliding resistance of concrete on the various foundation materials. For this design procedure, the sliding resistance has been assumed to be constant for a JRC pavement cast either directly on the subgrade, on a stabilized or nonstabilized base course, or on an existing flexible pavement. The maximum allowable width  $W$  or length  $L$  of JRC pavement slab will be determined from the following equation:

$$W \text{ or } L = 0.0777 \sqrt[3]{h_{dr}(f_s S)^2}$$

The formula above has been expressed on the nomograph (fig 3-1) for steel yield strengths  $f_s$  of 56,000 and 60,000 psi and the maximum  $W$  or  $L$  can be obtained from the intersection of a straight line drawn between the values of  $h_{dr}$  and  $S$  that will be used for the JRC pavement. The width of JRC pavement will generally be controlled by the concrete paving equipment and will normally be 25 feet, unless smaller widths are necessary to meet dimensional requirements.

c. Limitations to JRC pavement design procedure. The design procedure for JRC pavements presented herein has been developed from a limited amount of investigational and performance data. Consequently, the following limitations are imposed:

- (1) No reduction in the required thickness of JC pavement will be allowed for percentages of steel reinforcement less than 0.05.
- (2) No further reduction in the required thickness of JC pavement will be allowed over that indicated for 0.5 percent steel reinforcement in figure 3-1 regardless of the percent steel used.
- (3) The maximum width or length of JRC pavement slab will not exceed 100 feet regardless of the percent steel used or slab thickness.
- (4) The minimum thickness of JRC pavement or JRC overlay will be 6 inches.

9 Apr 84

3-3. Reinforcement to control pavement cracking. Reinforcement is mandatory in certain areas of JC pavements to control or minimize the effects of cracking. The reinforcing steel holds cracks tightly closed, thereby preventing spalling at the edges of the cracks and progression of the cracks into adjacent slabs. For each of the following conditions, the slabs or portions of the slabs will be reinforced with 0.05 percent steel in two directions normal to each other unless otherwise specified.

a. Odd-shaped slabs. It is often necessary in the design of pavement facilities to resort to odd-shaped slabs. Unless reinforced, these odd-shaped slabs often crack and eventually spall along the cracks, producing debris that is objectionable from operational and maintenance viewpoints. In addition, the cracks may migrate across joints into adjacent slabs. In general, a slab is considered to be odd-shaped if the longer dimension exceeds the shorter one by more than 25 percent or if the joint pattern does not result in essentially a square or rectangular slab. Figure 3-2 presents typical examples of odd-shaped slabs requiring reinforcement.

b. Mismatched joints. Steel reinforcement in the slabs is mandatory to prevent migration of cracks into adjacent pavements for the following two conditions of mismatched joints:

(1) Where joint patterns of abutting pavement facilities do not match, a partial reinforcement of slabs may be necessary. In such a condition, the mismatch of joints can cause a crack to form in the adjacent pavement unless there is a sufficient width of bond-breaking medium installed in the joint. The determination relative to utilizing reinforcement at mismatched joints in such junctures is based upon the type joint between the two pavement sections. A partial reinforcement of the slab, as described below, is required when the joint between the abutting pavement is one of the following: doweled construction joint, keyed construction joint, thickened-edge butt joint without a bond-breaking medium, doweled expansion joint, and thickened-edge slip joint with less than 1/4-inch bond-breaking medium. Reinforcement is not required if the joint between the abutting pavement facilities is either a thickened-edge expansion joint or a thickened-edge slip joint with 1/4 inch or more of bond-breaking medium, except for a mismatch of joints in the center 75-foot width of runway where reinforcement of the slabs of mismatched joints will be required regardless of the type of joint between the facilities. When reinforcement at mismatched joints is required, the slab in the pavement facility directly opposite the mismatched joint will be reinforced with the minimum 0.05 percent steel. The reinforcing steel will be placed in two rectangular directions for a distance 3 feet back from the juncture and for the full width or length of the slab in a direction normal to the mismatched joint. When a new pavement is being constructed abutting an existing pavement, the new slab opposite mismatched joints will be reinforced in the manner described above. When two abutting facilities

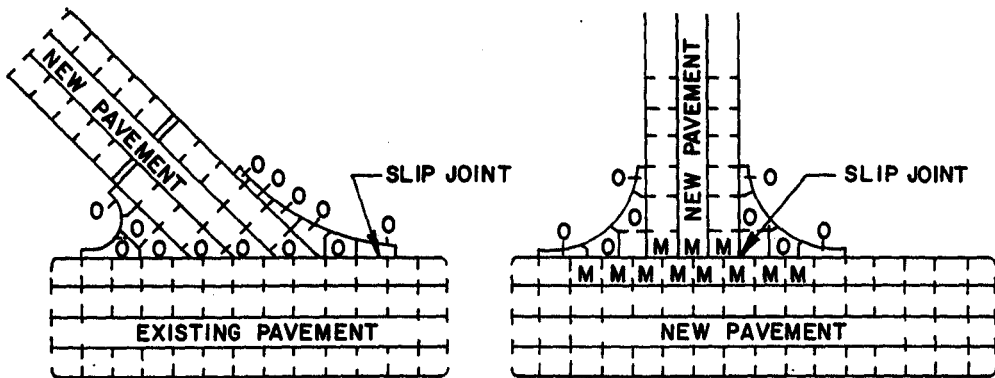
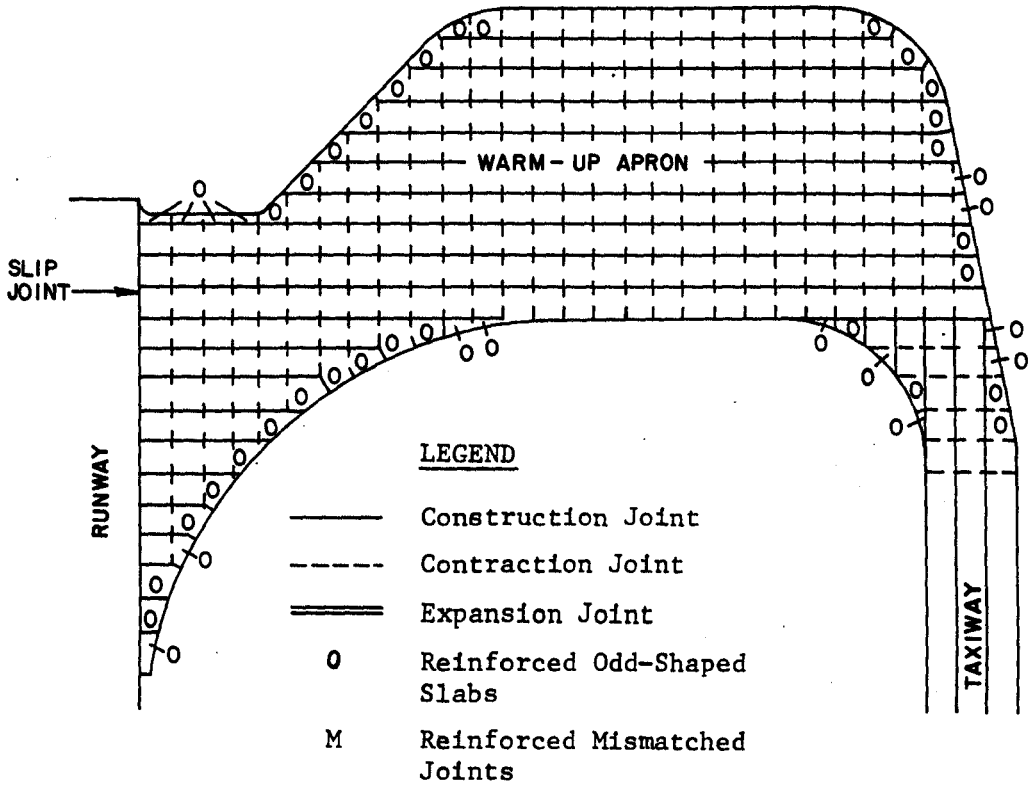

U. S. Army Corps of Engineers

FIGURE 3-2. TYPICAL LAYOUTS SHOWING REINFORCEMENT OF ODD-SHAPED SLABS AND MISMATCHED JOINTS

9 Apr 84

are being constructed concurrently, the slabs on both sides of the juncture opposite mismatched joints will be reinforced in the manner described above. For this condition shown in figure 3-2, the slip joint bond-breaking medium can be specified to be a full 1/4 inch thick, and the reinforcing may be omitted.

(2) The second condition of mismatched joints where reinforcement is required occurs in the construction of a JC overlay of an existing rigid pavement. Joints in the overlay should coincide with joints in the base pavement. Sometimes this is impracticable due to an unusual jointing pattern in the existing pavement. When necessary to mismatch the joints in the overlay and the existing pavement, the overlay pavement will be reinforced with the minimum 0.05 percent steel. The steel will be placed in two rectangular directions for a distance of at least 3 feet on each side of the mismatched joint in the existing pavement. The steel will, however, not be carried through any joint in the overlay except as permitted or required by paragraph 3-6. If the joint pattern in the existing pavement is highly irregular, or runs at an angle to the desired pattern in the overlay, the entire overlay slabs will be reinforced in both the longitudinal and transverse directions. When a bond-breaker course is placed between the existing pavement and overlay, reinforcement of the overlay over mismatched joints is not required, except for mismatched expansion joints.

c. Reinforcement of pavements incorporating heating pipes. JC pavements, such as hangar floors that incorporate radiant heating systems within the concrete, are subject to extreme temperature changes. These temperature changes cause thermal gradients in the concrete that result in stresses of sufficient magnitude to cause surface cracking. To control such cracking, these pavement slabs will be reinforced with a minimum of 0.05 percent steel placed in the transverse and longitudinal directions.

d. Reinforcement of slabs containing utility blockouts. The minimum of 0.05 percent steel reinforcement is required in JC pavement slabs containing utility blockouts, such as for hydrant refueling outlets, storm drain inlets, and certain types of flush lighting fixtures. The entire slab or slabs containing the blockouts will be reinforced in two rectangular directions.

3-4. JRC pavements in frost areas. Normally, JC pavements in frost areas will be designed in accordance with EM 1110-3-138 and reinforcement will be unnecessary. There may, however, be special instances when it will be directed that the frost design criteria will not be used. Typical of such instances are: design of new pavements to the strength of existing pavement when the existing pavement does not meet the frost design requirements, and design of an inlay section of adequate strength pavement in the center portion of an existing runway when the existing pavement does not meet the frost design



requirements. In such instances, the new pavements will be reinforced with a minimum of 0.15 percent steel. The minimum 0.15 percent steel will be placed in each of two directions (transverse and longitudinal) in the slab. The reinforcing steel is required primarily to control cracking that may develop because of differential heaving. The pavement thickness may be reduced and the maximum slab length, consistent with the percent steel, may be used as outlined in paragraph 3-3. Longer slabs will help reduce roughness that may result from frost action. Greater percentages of steel reinforcement may be used when it is desired to reduce the pavement thickness more than is allowable for the required minimum percentage of steel. Reinforced rigid pavement may be considered in frost areas to reduce the required depth of nonfrost-susceptible base course material. However, reinforcement will only be considered for this condition when there is an inadequate source of suitable base course materials or when special processing of existing materials would be required.

### 3-5. Reinforcement steel.

a. Type of reinforcement steel. The reinforcement steel may be either deformed bars or welded wire fabric. Table 3-1 summarizes the cross-sectional areas and weights of wires.

b. Placement of reinforcement steel. The reinforcement steel will be placed at a depth of  $1/4 h_{dr}$  plus 1 inch from the surface of the reinforced slab. This will place the steel above the neutral axis of the slab and will allow clearance for dowel bars. The wire or bar sizes and spacing should be selected to give, as nearly as possible, the required percentage of steel per foot of pavement width or length. In no case should the percent steel used be less than that required by figure 3-1. Two layers of wire fabric or bar mat, one placed directly on top of the other, may be used to obtain the required percent of steel; however, this should only be done when it is impracticable to provide the required steel in one layer. If two layers of steel are used, the layers must be fastened together (either wired or clipped) to prevent excessive separation during concrete placement. When the reinforcement is installed and concrete is to be placed through the mat or fabric, the minimum clear spacing between bars or wires will be 1-1/2 times the maximum size of aggregate. If the strike-off method is used to place the reinforcement (layer of concrete placed and struck off at the desired depth, the reinforcement placed on the plastic concrete, and the remaining concrete placed on top of the reinforcement), the minimum spacing of wires or bars will not be less than the maximum size of aggregate. Maximum bar or wire spacing should not exceed 12 inches or the slab thickness. Figure 3-3 shows the typical details of slab reinforcement with wire fabric or bar mats. The bar mat or wire fabric will be securely anchored to prevent forward creep of the steel mats during concrete placement and finishing operations. The reinforcement shall be fabricated and placed in such a manner that the spacing between the longitudinal wire or bar and the

Table 3-1. Welded Wire Fabrics

| <u>Size<br/>No.</u> | <u>Nominal Diameter,<br/>inches</u> | <u>Nominal Area,<br/>square inches</u> |
|---------------------|-------------------------------------|--|
| W 31                | 0.628                               | 0.310                                  |
| W 30                | 0.618                               | 0.300                                  |
| W 28                | 0.597                               | 0.280                                  |
| W 26                | 0.575                               | 0.260                                  |
| W 24                | 0.553                               | 0.240                                  |
| W 22                | 0.529                               | 0.220                                  |
| W 20                | 0.505                               | 0.200                                  |
| W 18                | 0.479                               | 0.180                                  |
| W 16                | 0.451                               | 0.160                                  |
| W 14                | 0.422                               | 0.140                                  |
| W 12                | 0.391                               | 0.120                                  |
| W 10                | 0.357                               | 0.100                                  |
| W 8                 | 0.319                               | 0.080                                  |
| W 7                 | 0.299                               | 0.070                                  |
| W 6                 | 0.276                               | 0.060                                  |
| W 5.5               | 0.265                               | 0.055                                  |
| W 5                 | 0.252                               | 0.050                                  |
| W 4.5               | 0.239                               | 0.045                                  |
| W 4                 | 0.226                               | 0.040                                  |
| W 3.5               | 0.211                               | 0.035                                  |
| W 3                 | 0.195                               | 0.030                                  |
| W 2.5               | 0.178                               | 0.025                                  |
| W 2                 | 0.160                               | 0.020                                  |
| W 1.5               | 0.138                               | 0.015                                  |
| W 1.2               | 0.124                               | 0.012                                  |
| W 1                 | 0.113                               | 0.010                                  |
| W 0.5               | 0.080                               | 0.005                                  |

U. S. Army Corps of Engineers

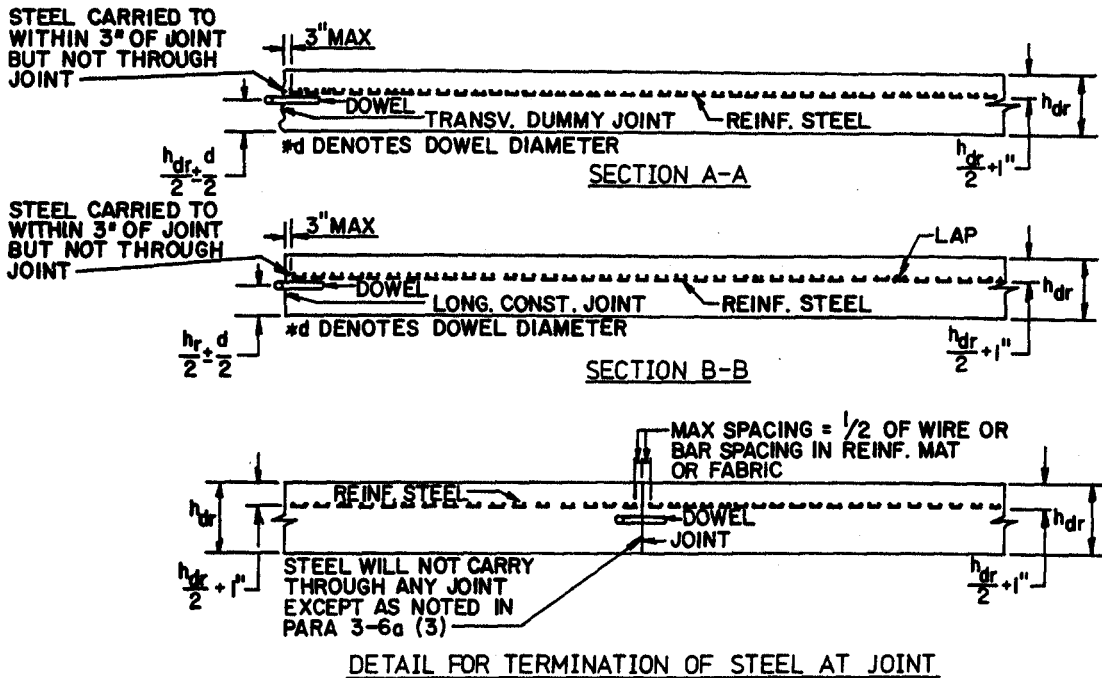
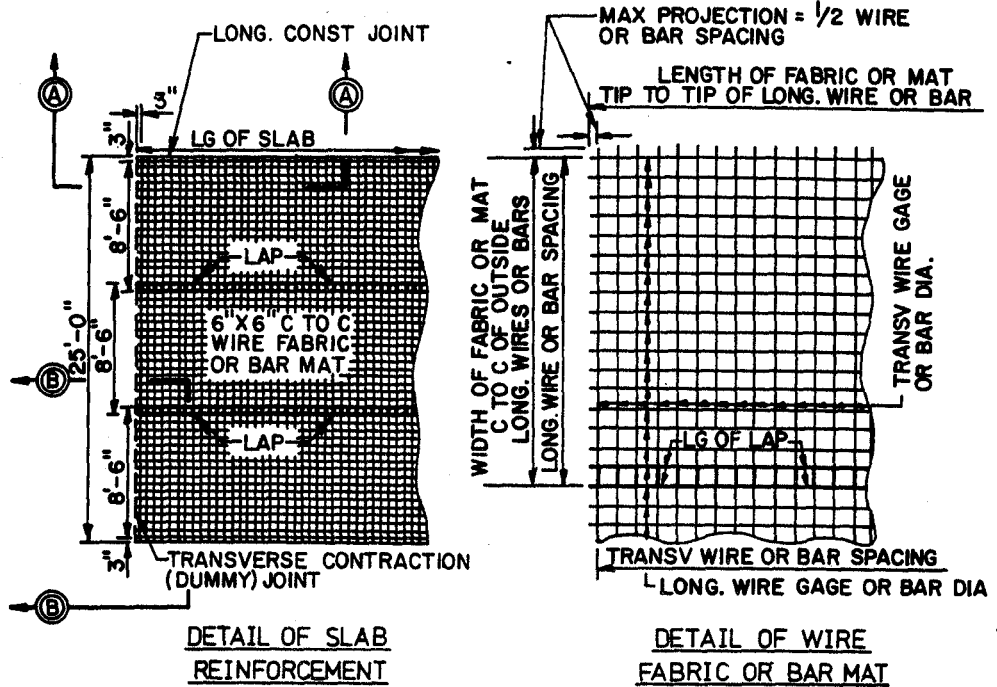

- DETAIL FOR TERMINATION OF STEEL AT JOINT
- NOTES: 1.  $h_{dr}$  denotes JRC pavement design thickness.
2. Reinforced steel will not be carried through any joint except as noted in para 3-6a.
3. All joints in JRC pavements doweled except as noted in para 3-6a.
4. Dowel size, spacing and length determined from para 2-3a(5) using JRC pavement thickness,  $h_{dr}$ .

U. S. Army Corps of Engineers

FIGURE 3-3. REINFORCEMENT STEEL DETAILS

longitudinal joint, or between the transverse wire or bar and the transverse joint, will not exceed 3 inches or one half of the wire or bar spacing in the fabric or mat (fig 3-3). The wires or bars will be lapped as follows:

(1) Deformed steel bars will be overlapped for a distance of at least 24-bar diameters, measured from the tip of one bar to the tip of the other bar. The lapped bars will be wired or otherwise securely fastened to prevent separation during concrete placement.

(2) Wire fabric will be overlapped for a distance equal to at least one spacing of the wire in the fabric or 32-wire diameters, whichever is the greater. The length of lap is measured from the tip of one wire to the tip of the other wire normal to the lap. The wires in the lap will be wired or otherwise securely fastened to prevent separation during concrete placement.

### 3-6. Jointing.

a. Requirements. Figures 3-4 through 3-6 present details of joints in JRC pavements. Joint requirements and types in JRC pavement will be the same as for the JC pavements except for the following:

(1) All joints, with the exception of thickened-edge-type joints and transverse construction joints, falling at a point other than at a regularly scheduled transverse contraction joint, will be doweled. One end of the dowel will be painted and oiled or greased to permit movement at the joint.

(2) Thickened-edge-type joints (expansion, butt, or slip) will not be doweled. The edge will be thickened to  $1-1/4 h_{dr}$ .

(3) When a transverse construction joint is required within a reinforced slab unit, the reinforcing steel will be carried through the joint. In addition, dowels meeting the size and spacing requirements of table 3-1 for the design thickness  $h_{dr}$  will be used in the joint.

(4) Maximum spacing of transverse contraction joints or longitudinal construction joints will be determined in accordance with paragraphs 2-3a and 2-3b.

b. Joint sealing. Joint sealing for JRC pavements will be the same as for the JC pavements (para 2-3f). The use of preformed compression sealants will be required when the joint spacing exceeds 50 feet.

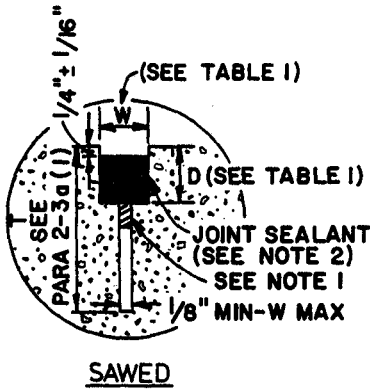
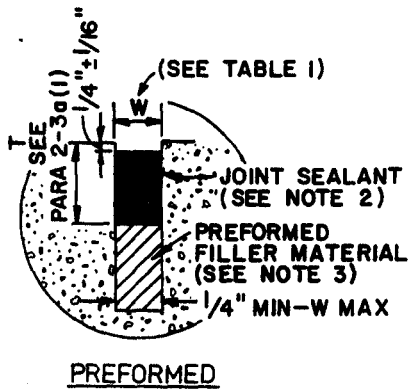

TABLE I

| CONTRACTION JOINT SPACING, ft. | DIMENSIONS, in. |                  |
|--------------------------------|-----------------|------------------|
|                                | W               | D                |
| <20                            | $3/8 \pm 1/16$  | $3/4 \pm 1/16$   |
| 20-25                          | $1/2 \pm 1/16$  | $1 \pm 1/16$     |
| >25-50                         | $3/4 \pm 1/16$  | $1-1/4 \pm 1/16$ |
| >50-100                        | $1 \pm 1/16$    | $1-1/2 \pm 1/16$ |



- NOTE: 1. Nonabsorptive material required to prevent joint sealant from flowing into sawcut and to separate noncompatible materials.
2. Joint sealant may be pourable or preformed type (see para 2-3e).
3. Preformed filler may be fiberboard or other approved material which can be sawed or which can have a section removed to form a sealant reservoir.

LONGITUDINAL

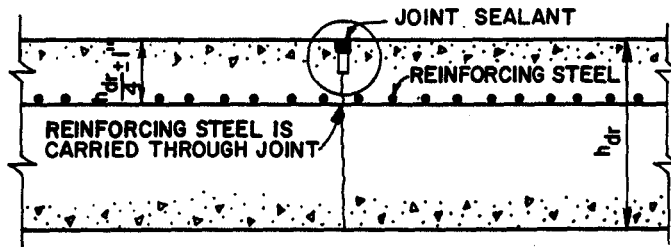

TRANSVERSE

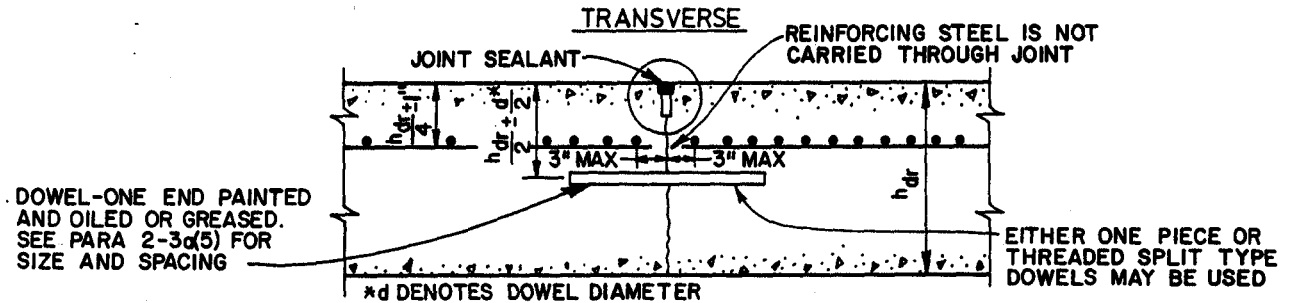

U. S. Army Corps of Engineers

FIGURE 3-4. CONTRACTION JOINTS FOR JRC PAVEMENTS

9 Apr 84

**DOWELED TRANSVERSE (1)**

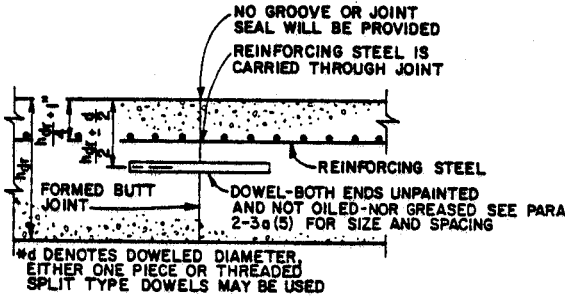

NOTE: 1. This detail will be used only when a transverse construction joint is required at a location other than a regularly scheduled transverse contraction joint.

**KEYED AND TIED LONGITUDINAL**

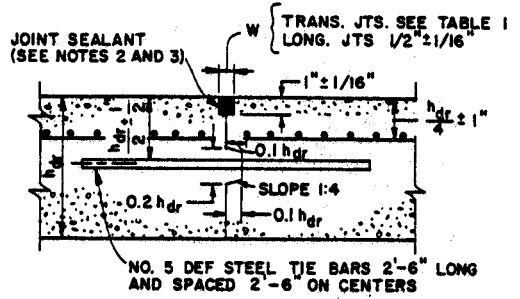

NOTE: A tolerance of plus or minus 1/16 inch may be allowed for key dimensions and location.

**THICKENED EDGE LONGITUDINAL**

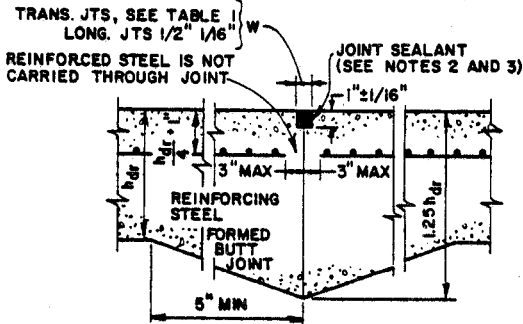

**DOWELED TRANSVERSE (4) OR LONGITUDINAL**

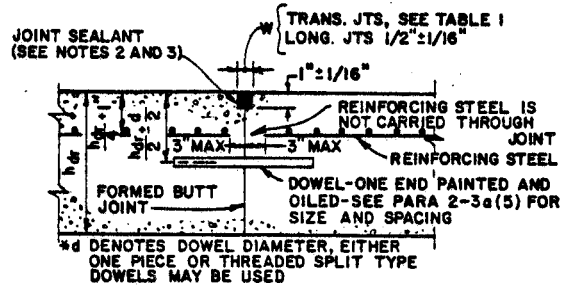

NOTE: 4. This detail will be used when a transverse construction joint is required at a regularly scheduled transverse contraction joint.

**KEYED THICKENED EDGE LONGITUDINAL**

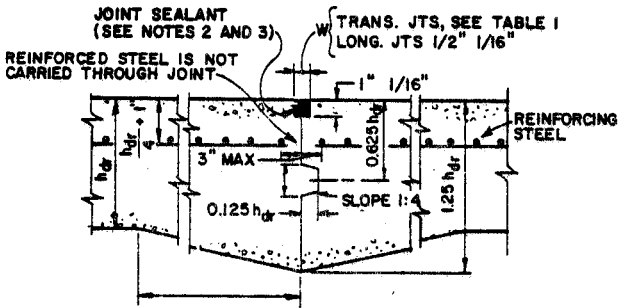

NOTE: A tolerance of plus or minus 1/16 inch may be allowed for key dimensions and location.

**SPECIAL JOINT BETWEEN NEW AND EXISTING PAVEMENTS**

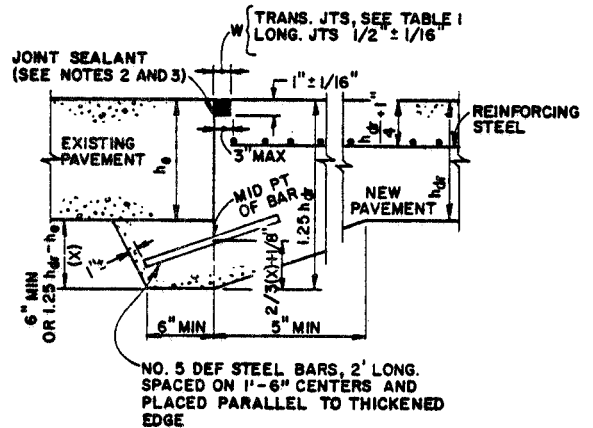

NOTE: 2. Top of joint sealant will be 1/4 inch plus or minus 1/16 inch below top of pavement.

NOTE: 3. Joint sealant may be pourable or preformed type (See para 2-3e).

TABLE I

| DISTANCE BETWEEN JOINTS (SLAB LENGTH) OR WIDTH) FT | W INCHES | D INCHES |
|--|----------|----------|
| UP TO 50   | 1/2 1/8  | 1/2 1/8  |
| 51 TO 100  | 3/4 1/8  | 3/4 1/8  |

U. S. Army Corps of Engineers

FIGURE 3-5. CONSTRUCTION JOINTS FOR JRC PAVEMENTS



## CHAPTER 4

### JOINTED FIBROUS CONCRETE (JFC) PAVEMENT DESIGN

4-1. Basis of design. The design of JFC pavement is based upon limiting the ratio of the concrete flexural strength and the maximum tensile stress at the joint, with the load either parallel or normal to the edge of the slab, to a value found to give satisfactory performance in full-scale accelerated test tracks. Because of the increased flexural strength and tenacity at cracks that develop in the fibrous concrete, the thickness can be significantly reduced; however, this results in a more flexible structure, which causes an increase in vertical deflections as well as in the potential for densification and/or shear failures in the foundations, pumping of the subgrade material, and joint deterioration. To protect against these latter factors, a limiting vertical deflection criterion has been applied to the thickness developed from the tensile stress criteria.

4-2. Uses. Although several types of fiber have been studied for concrete reinforcement, most of the experience has been with steel fibers, and the design criteria presented herein are limited to steel fibrous concrete. Fibrous concrete is a relatively new material for pavement construction and lacks a long-time performance history. The major uses to date have been for thin resurfacing or strengthening overlays where grade problems restrict the thickness of overlay that can be used. The use of JFC pavement should be based upon the time saved and the availability of the materials involved.

4-3. Mix proportioning considerations. The design mix proportioning of fibrous concrete will be determined by field testing when time is available. Otherwise, preliminary estimates must be made. The following are offered as guides and establish limits where necessary for the use of the design criteria included herein.

a. The criteria contained herein are based upon fibrous concrete containing 1 to 2 percent by volume (100 to 250 pounds) of steel fibers per cubic yard of concrete, and fiber contents within this range are recommended.

b. Most experience to date has been with fibers 1 to 1-1/2 inches long, and for use of the criteria herein, fiber lengths within this range are recommended.

c. For proper mixing, the maximum aspect ratio (length to diameter or equivalent diameter) of the fibers should be about 100.

d. The large surface area to volume ratio of the steel fibers requires an increase in the paste necessary to insure that the fibers and aggregates are coated. To accomplish this, cement contents of 750 to 900 pounds per cubic yard of concrete are recommended. The cement



content may be all portland cement or a combination of portland cement and up to 25 percent fly ash or other pozzolans.

e. Maximum size coarse aggregates should fall between 3/8 and 3/4 inch. The percent of coarse aggregate (of the total aggregate content) can vary between 25 and 60 percent.

4-4. Thickness determination. The required thickness of JFC pavement will be a function of the design concrete flexural strength  $R$ , the modulus of soil reaction  $k$ , the thickness  $h_p$  and flexural modulus of elasticity  $E_{fs}$  of stabilized material if used, the aircraft gross load, the volume of traffic, the type of traffic area, and the allowable vertical deflection. When stabilized material is not used, the required thickness  $h_{df}$  of JFC is determined directly from the appropriate charts, figures 4-1 through 4-3 (curves for Air Force light, medium, heavy load, and short field, figures 4-4 through 4-7, are included for reference). If the base or subgrade is stabilized and meets the minimum strength requirements of EM 1110-3-137, the stabilized layer will be treated as a low-strength base, and the design will be made using the equation given in paragraph 2-2b of this manual. The resulting thickness,  $h_{df}$  or  $h_{dof}$ , will be rounded upward to the nearest half or full inch. The rounded thickness,  $h_{df}$  or  $h_{dof}$ , will then be checked for allowable deflection in accordance with paragraph 4-5. The minimum thickness for JFC pavements will be 4 inches.

4-5. Allowable deflection for JFC pavement. The elastic deflection that JFC pavements experience must be limited to prevent overstressing of the foundation material and thus premature failure of the pavement. Curves are provided (fig 4-8 through 4-10) for the computation of the vertical elastic deflection that a pavement will experience when loaded. Use of the curves requires three different inputs: slab thickness, subgrade modulus, and gross weight of the design aircraft. The slab thickness is that which is determined from paragraph 4-4 above. The computed vertical elastic deflection is then compared with appropriate allowable deflections determined from table 4-1 or, in the case of shoulder design, with an allowable deflection value of 0.06 inch. If the computed deflection is less than the allowable deflection, the thickness meets allowable deflection criteria and is acceptable. If the computed deflection is larger than the allowable deflection, the thickness must be increased or a new design initiated with a different value for either  $R$  or  $k$ . The process must be repeated until a thickness based upon the limiting stress criterion will also have a computed deflection equal to or less than the allowable value.

9 Apr 84

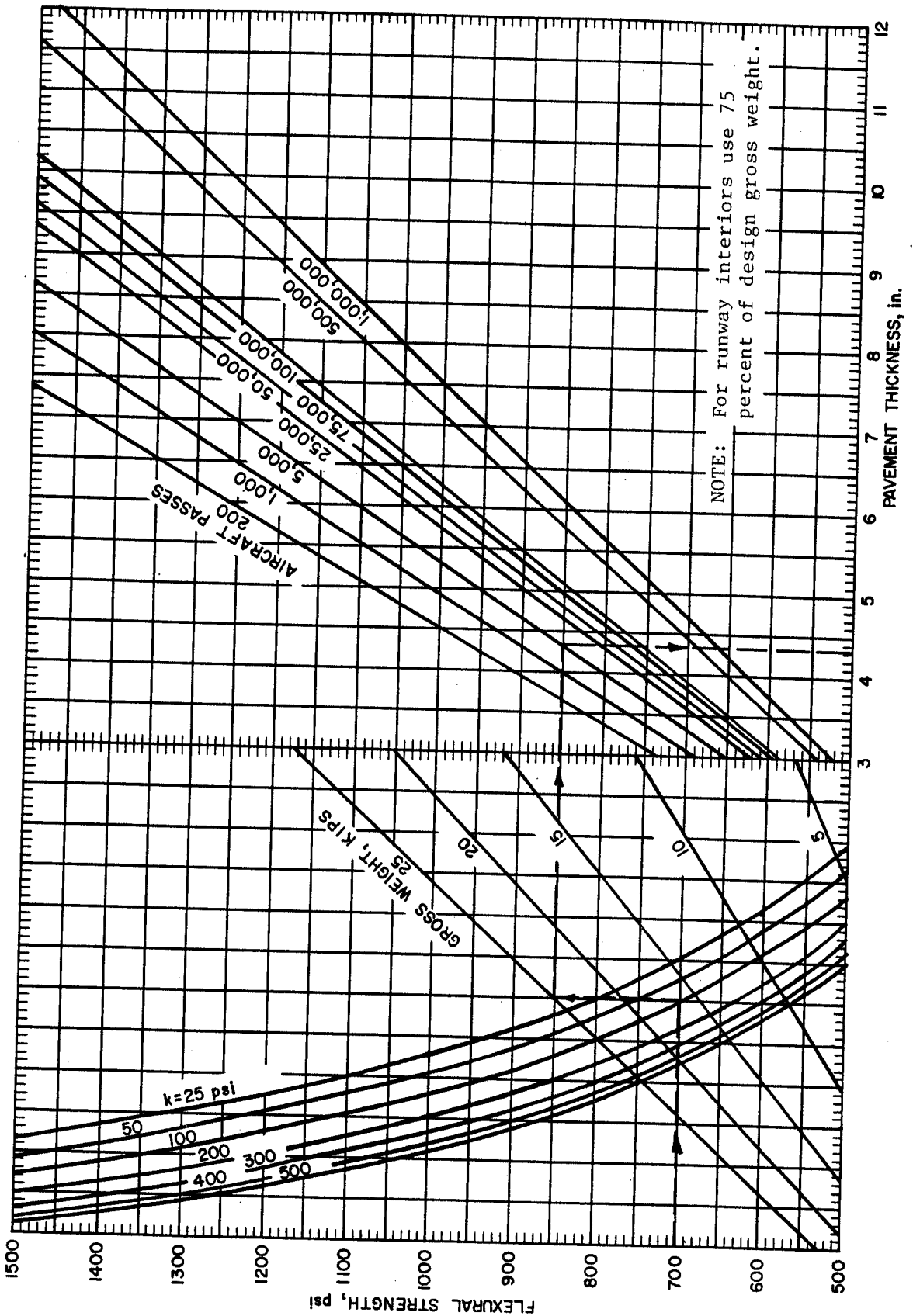

U. S. Army Corps of Engineers

FIGURE 4-1. FIBROUS CONCRETE PAVEMENT DESIGN CURVES FOR ARMY CLASS I PAVEMENTS

9 Apr 84

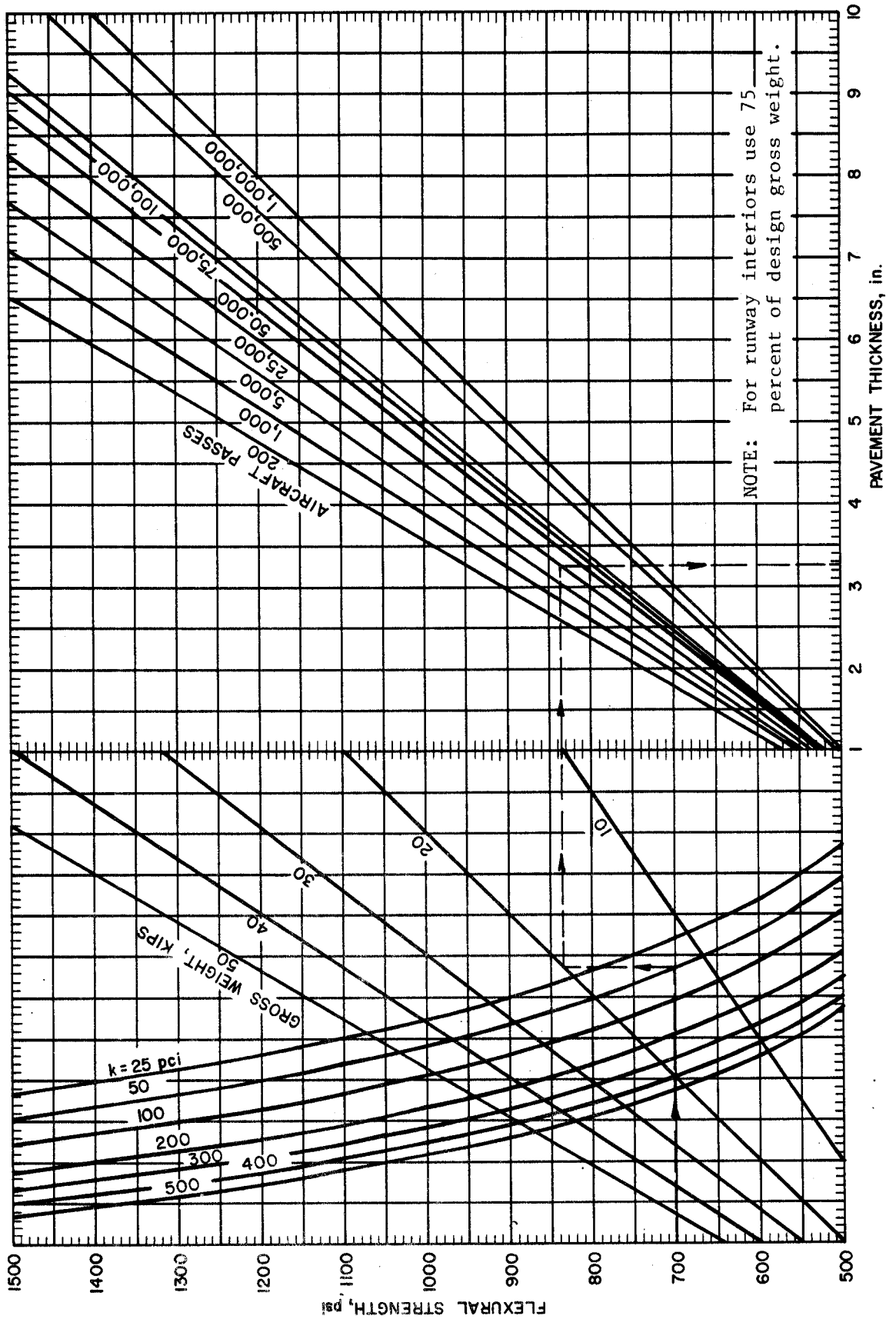

U. S. Army Corps of Engineers

FIGURE 4-2. FIBROUS CONCRETE PAVEMENT DESIGN CURVES FOR ARMY CLASS II PAVEMENTS

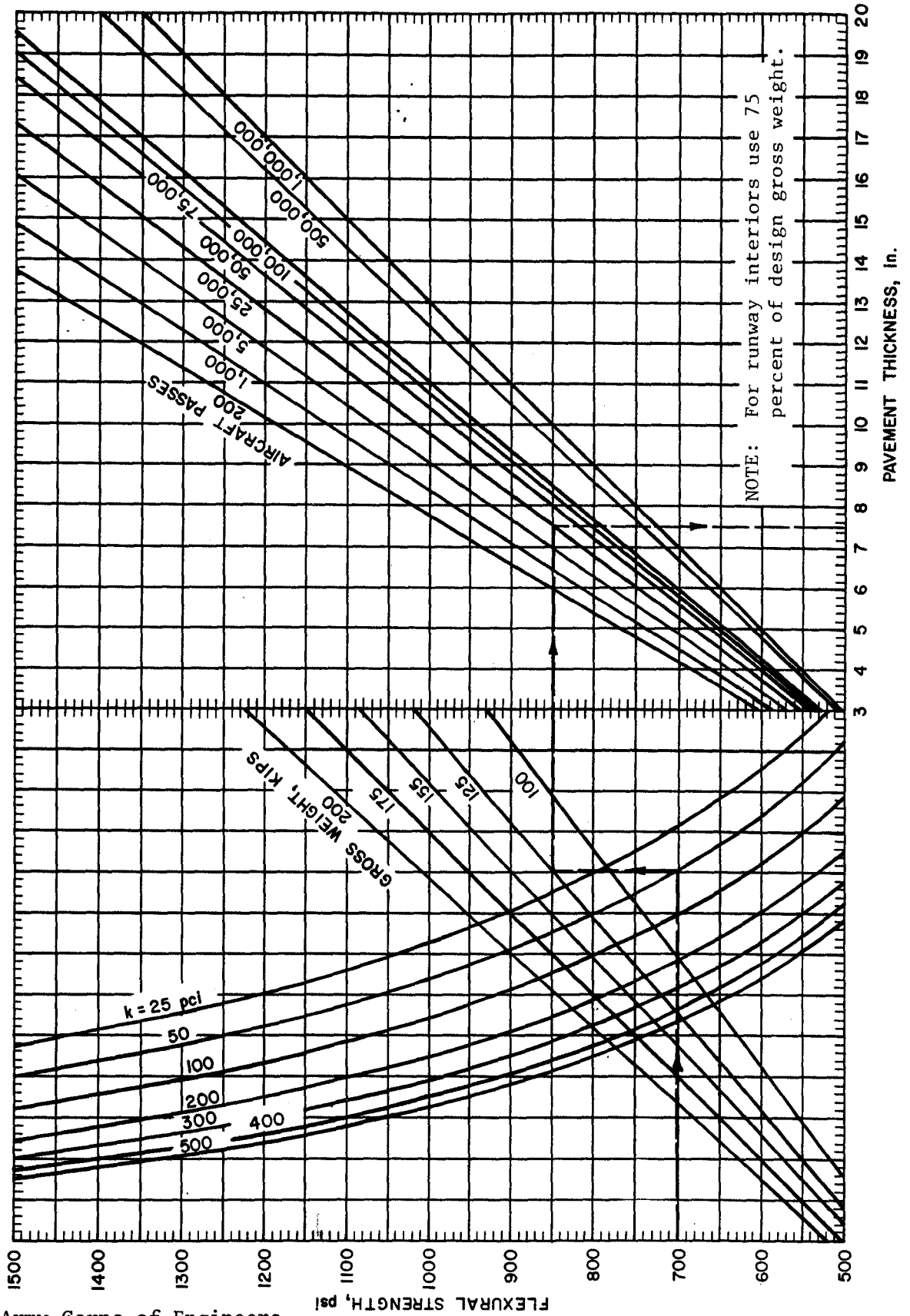

U. S. Army Corps of Engineers

FIGURE 4-3. FIBROUS CONCRETE PAVEMENT DESIGN CURVES FOR ARMY CLASS III PAVEMENTS

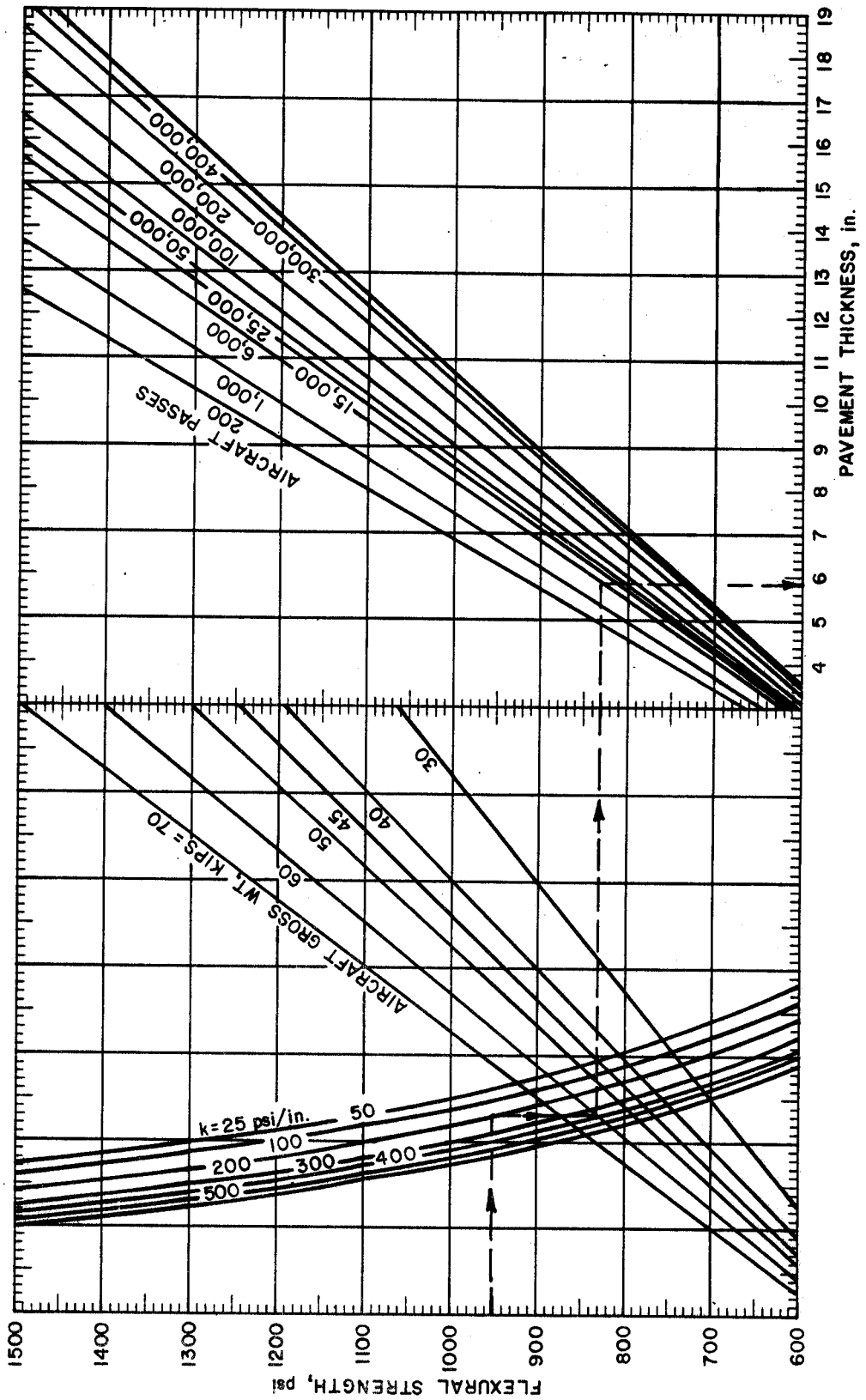

U. S. Army Corps of Engineers

FIGURE 4-4. FIBROUS CONCRETE PAVEMENT DESIGN CURVES  
FOR AIR FORCE LIGHT-LOAD PAVEMENTS

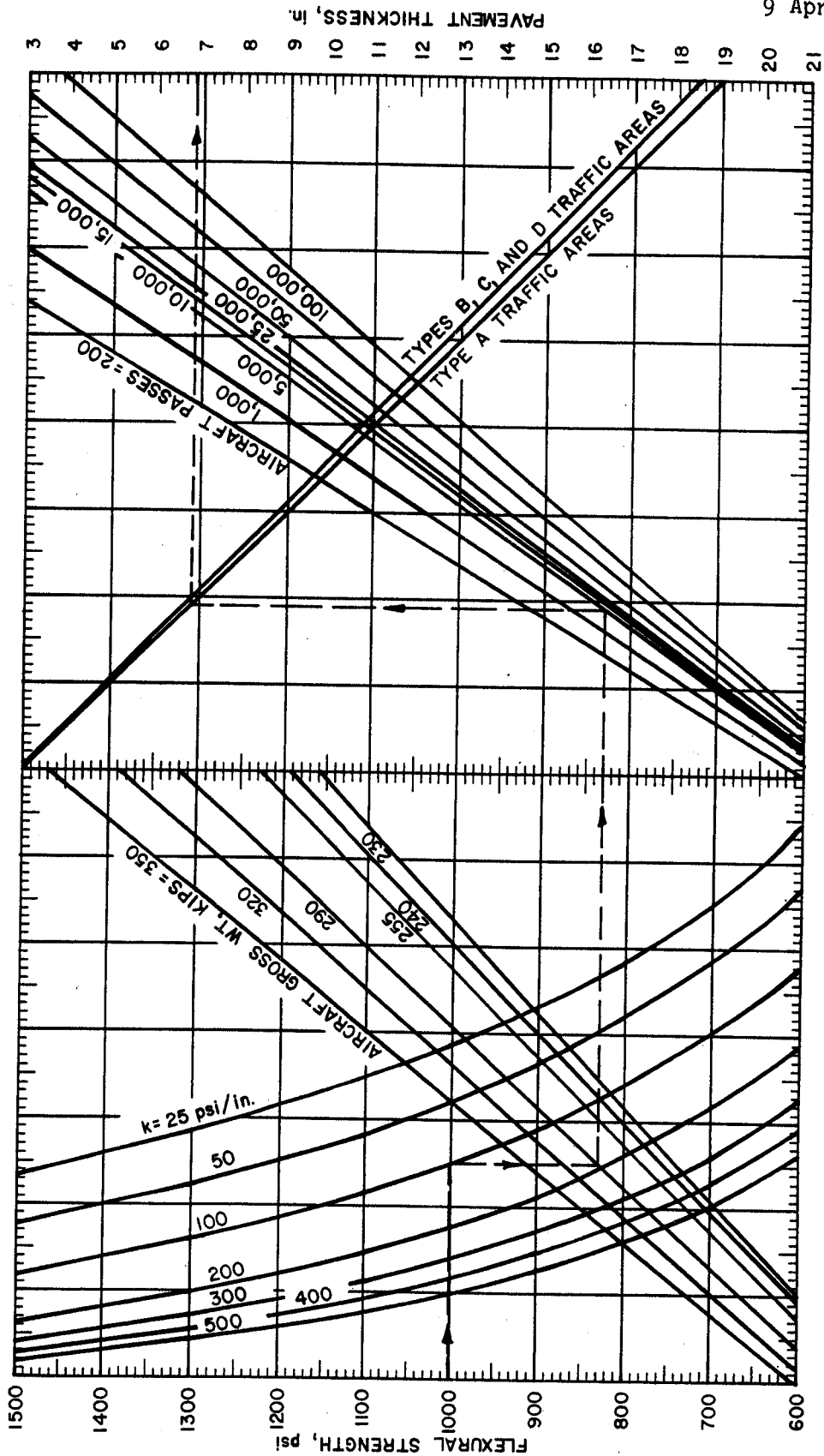

U. S. Army Corps of Engineers

FIGURE 4-5. FIBROUS CONCRETE PAVEMENT DESIGN CURVES  
FOR AIR FORCE MEDIUM-LOAD PAVEMENTS

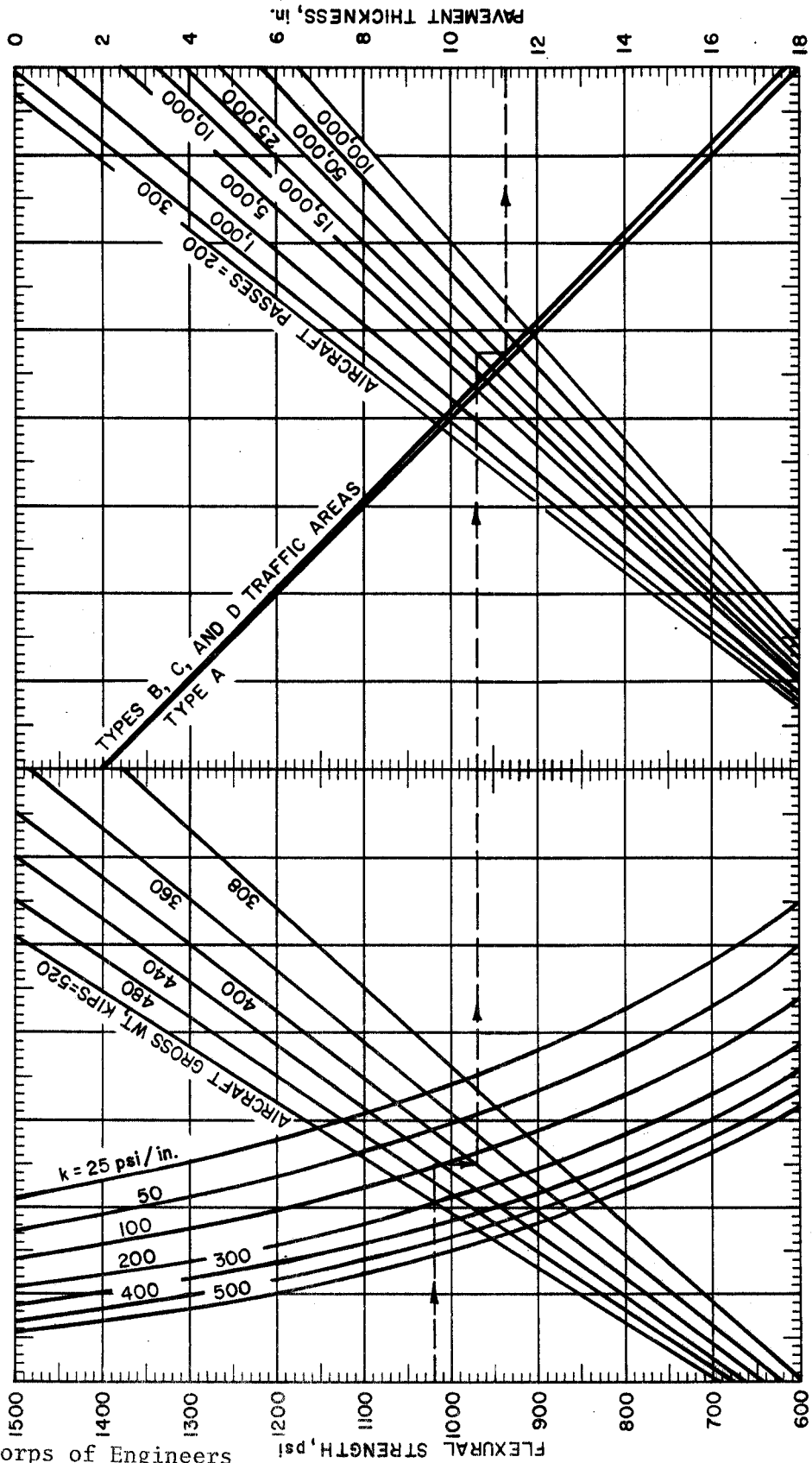

U. S. Army Corps of Engineers  
 FIGURE 4-6. FIBROUS CONCRETE PAVEMENT DESIGN CURVES  
 FOR AIR FORCE HEAVY-LOAD PAVEMENTS

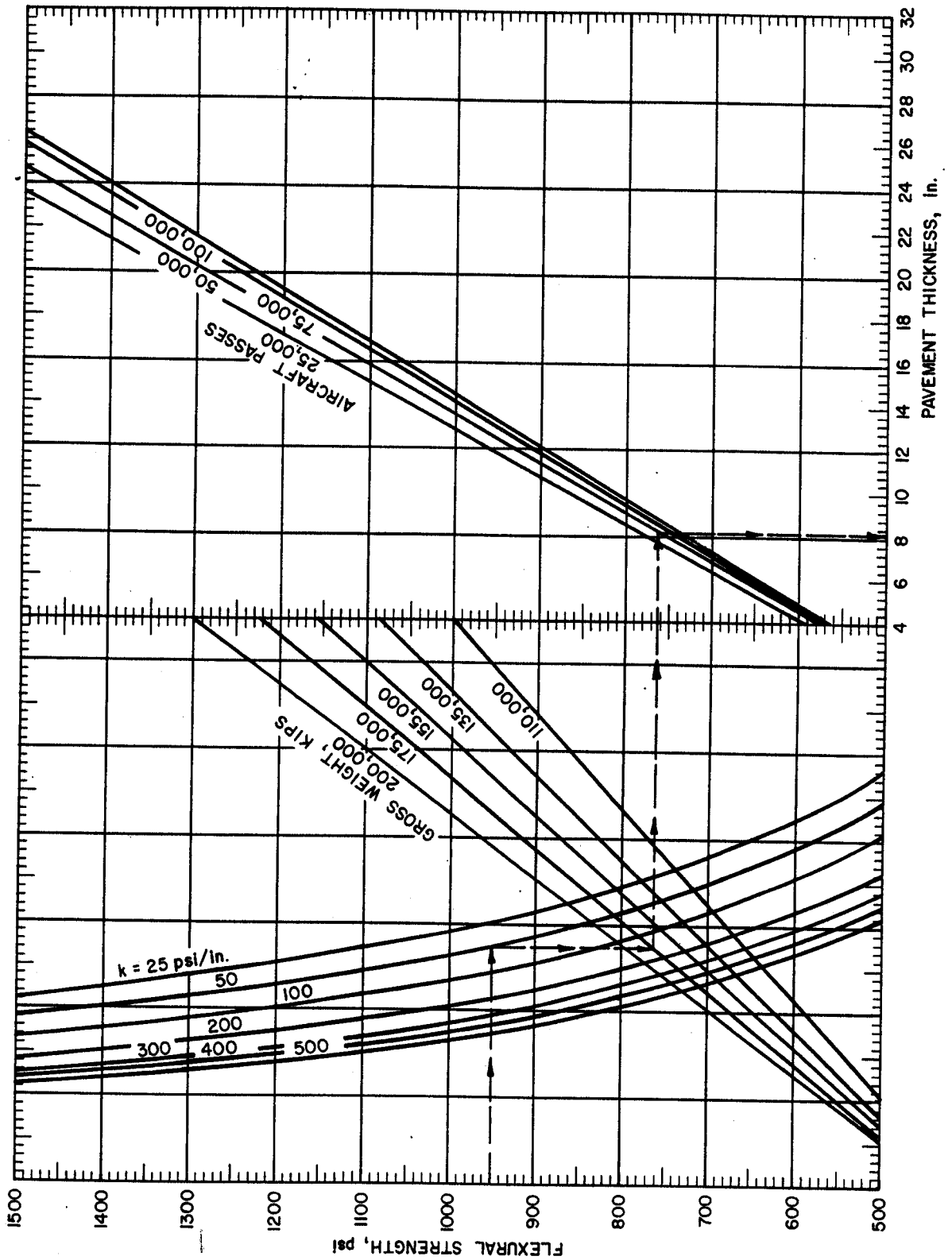

U. S. Army Corps of Engineers

FIGURE 4-7. FIBROUS CONCRETE PAVEMENT DESIGN CURVES  
FOR AIR FORCE SHORT FIELD PAVEMENTS



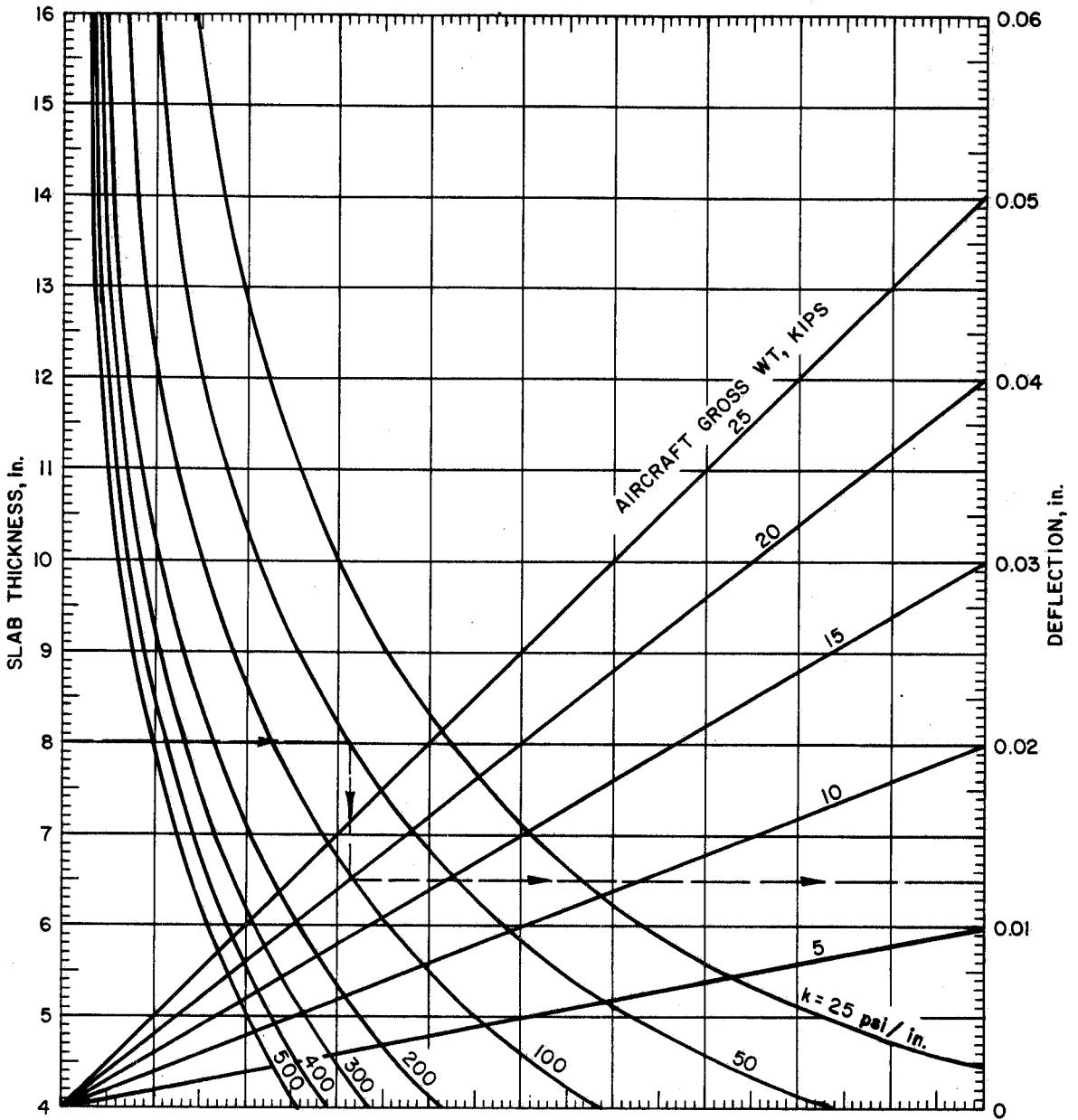

U. S. Army Corps of Engineers

FIGURE 4-8. DEFLECTION CURVES FOR CLASS I PAVEMENTS

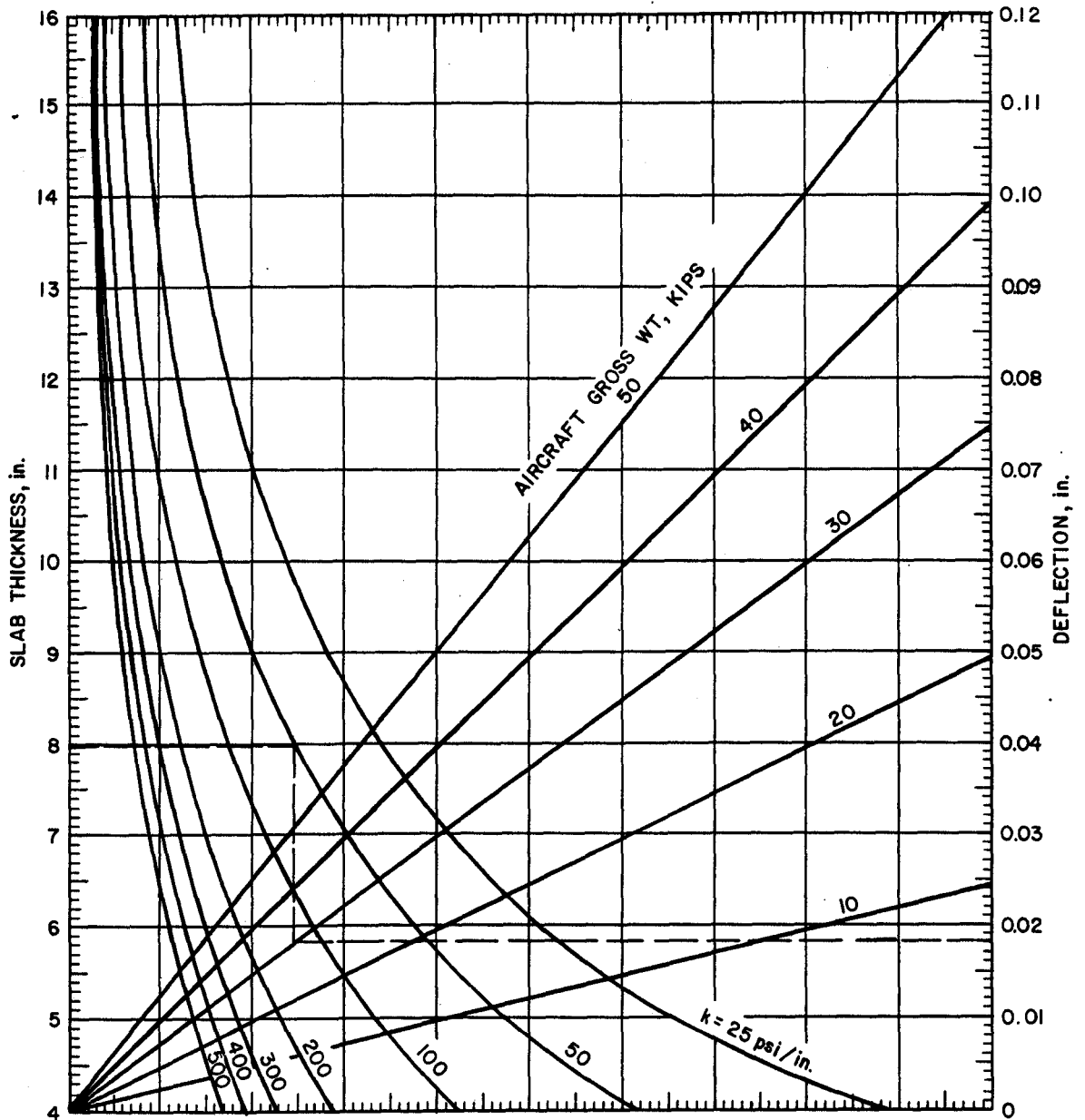

U. S. Army Corps of Engineers

FIGURE 4-9. DEFLECTION CURVES FOR CLASS II PAVEMENTS

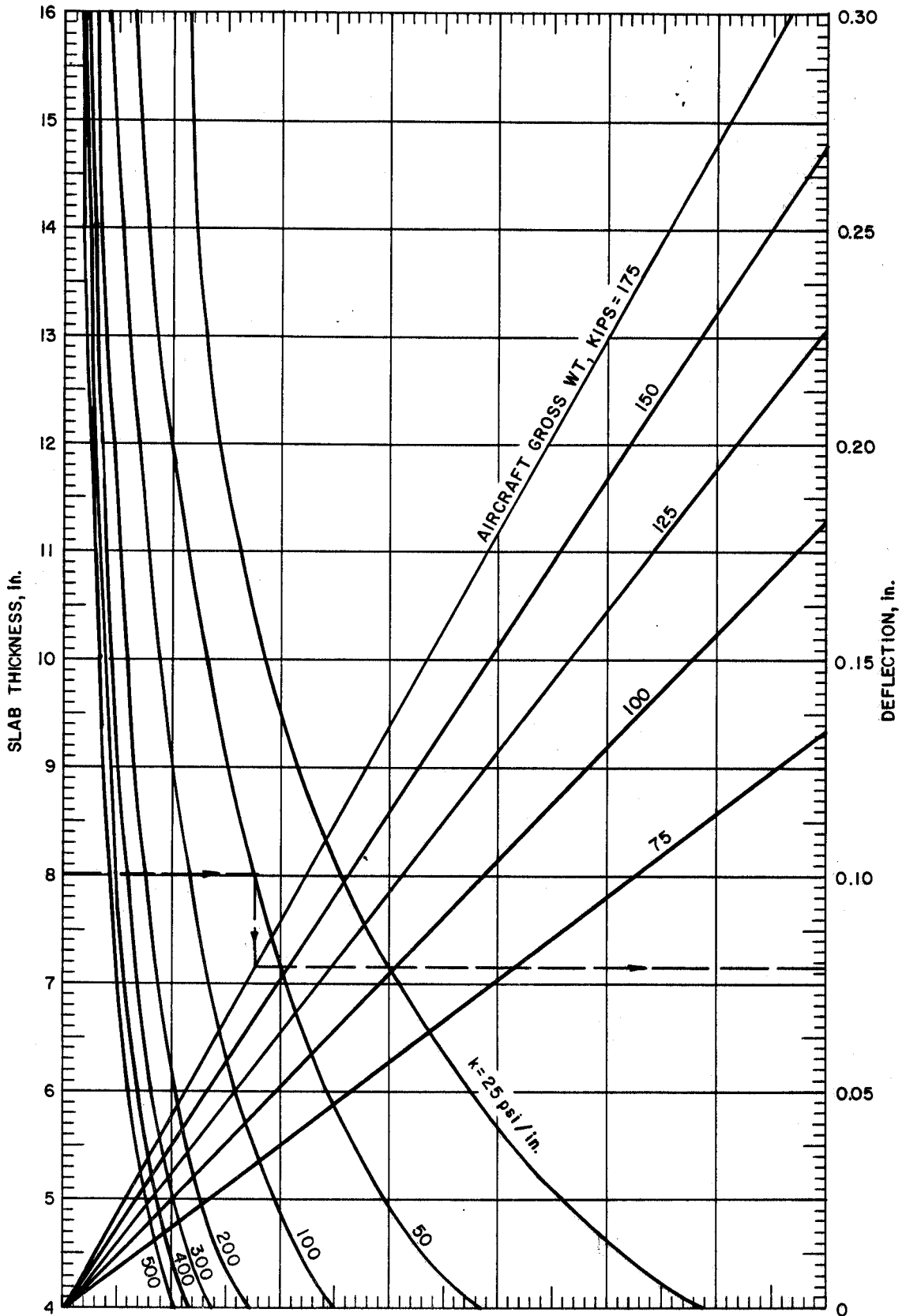

U. S. Army Corps of Engineers

FIGURE 4-10. DEFLECTION CURVES FOR CLASS III PAVEMENTS

Table 4-1. Limiting Elastic Deflections for JFC Pavements

| Traffic<br>Passes | Limiting Deflection, In. |          |           |
|-------------------|--------------------------|----------|-----------|
|                   | Class I                  | Class II | Class III |
| 200               | .180                     | .155     | .155      |
| 1,000             | .130                     | .110     | .110      |
| 5,000             | .090                     | .075     | .075      |
| 25,000            | .065                     | .060     | .060      |
| 50,000            | .060                     | .055     | .055      |
| 75,000            | .055                     | .050     | .050      |
| 100,000           | .055                     | .050     | .050      |
| 500,000           | .050                     | .050     | .050      |
| 1,000,000         | .050                     | .050     | .050      |

4-6. Jointing. The joint types and designs discussed in paragraph 2-3 generally apply to JFC pavement. The tenacity of the fibrous concrete does afford some variations in allowable joint spacings, and the maximum joint spacing becomes a function of the load-transfer mechanism. For the mix proportionings discussed in paragraph 4-3, the maximum spacing of joints (transverse and/or longitudinal) will be as follows:

| <u>Thickness, inches</u> | <u>Maximum Spacing, feet</u> |                  |
|--------------------------|------------------------------|------------------|
|                          | <u>Doweled</u>               | <u>Undoweled</u> |
| 4 to 6                   | 50                           | 25               |
| Greater than 6           | 100                          | 50               |

Longitudinal construction joints may be either doweled, keyed and tied, or thickened-edge with a key, in which case the key dimensions will be based upon the thickened-edge thickness. The keyed and tied construction joint will be limited to a width of 100 feet. For widths greater than 100 feet, combinations of keyed and tied, doweled, or thickened-edge-type joints may be used. Sealing of joints in fibrous concrete will follow the criteria presented in paragraph 2-3f except that preformed compression sealants are recommended for joints spaced greater than 25 feet, and are required when the joint spacing exceeds 50 feet.

## CHAPTER 5

### OVERLAY PAVEMENT DESIGN

5-1.. General. Two general types of overlay pavement are considered: rigid and nonrigid. The procedures described will use rigid overlays to strengthen existing rigid or flexible pavements and nonrigid overlays to strengthen existing rigid pavements. Procedures are presented for the design of jointed concrete (JC), jointed reinforced concrete (JRC), fibrous concrete (FC), and nonrigid overlays. Nonrigid overlays include both flexible (nonstabilized base and bituminous concrete wearing course) and all-bituminous concrete for strengthening existing JC or JRC pavements. Flexible overlays will be used only when the nonstabilized aggregate base course can be positively drained. Resurfacing of rigid pavements with thin, bonded rigid overlays (less than 4 inches) are not to be considered for strengthening of existing pavements.

5-2. Site investigations. Explorations and tests of the existing pavement will be made to determine the structural condition of the existing pavement prior to overlay, assess the required physical properties of the existing pavement and foundation materials, and locate and analyze all existing areas of defective pavement and subgrade that will require special treatment. The determination of the structural condition and required physical properties of the existing pavement will depend upon the type of overlay used as described in subsequent paragraphs. An investigation will be conducted to determine whether there are any voids under the existing rigid pavement. This investigation is especially important if there has been, or is, any evidence of pumping or bleeding of water at cracks, joints, or edges of the existing rigid pavement. If voids are found under the existing rigid pavements, they will be grouted before the overlay is placed. The results of the investigation, especially the nondestructive tests, may show rather large variations in the strength of the existing pavement and may lead to more extensive testing to determine the cause of the variation. It will then be necessary to determine the feasibility and economics of using a variable thickness overlay, basing the design on the lower strength pavement section, or removing and replacing the low-strength pavement areas.

5-3. Preparation of existing pavement. The preparation of the existing pavement prior to overlay will depend upon the type of overlay, as follows:

a. Rigid overlay. Overlay thickness criteria are presented for two conditions of bond between the rigid overlay and existing rigid pavement: partially and nonbonded. The partially bonded condition is obtained when concrete is cast directly on concrete with no special efforts to achieve or destroy bond. The nonbonded condition is obtained when the bond is prevented by an intervening layer of

9 Apr 84

material. When a partially bonded rigid overlay is to be used, the existing rigid pavement will be cleaned of all foreign matter (oil, paint, etc.), spalled concrete, extruded joint seal, bituminous patches, or anything else that would act as a bond-breaker between the overlay and existing rigid pavement. When a nonbonded rigid overlay is being used, the existing rigid pavement will be cleaned of all loose particles and covered with a leveling or bond-breaking course of bituminous concrete, sand-asphalt, heavy building paper, polyethylene, or other similar stable material. The bond-breaking medium generally should not exceed a thickness of about 1 inch except in the case of leveling courses where greater thicknesses may be necessary. When a rigid overlay is being applied to an existing flexible pavement, the surface of the existing pavement will be cleaned of loose materials and any potholing or unevenness, exceeding about 1 inch, will be repaired by localized patching or the application of a leveling course using bituminous concrete, sand-asphalt, or similar material.

b. Nonrigid overlay. When a flexible overlay is used, no special treatment of the surface of the existing rigid pavement will be required, other than the removal of loose material. When an all-bituminous concrete overlay is used, the surface of the existing rigid pavement will be cleaned of all foreign matter, spalled concrete, fat spots in bituminous patches, and extruded soft or spongy joint seal material. Joints or cracks less than 1 inch wide in the existing rigid pavement will be filled with joint sealant. Joints or cracks that are 1 inch or greater in width will be cleaned and filled with an acceptable bituminous mixture (such as sand-asphalt) which is compatible with the overlay. Wedge courses of bituminous concrete will be used to bring the existing rigid pavement to proper grade when required. Prior to placing the all-bituminous concrete overlay, a tack coat will be applied to the surface of the existing pavement.

5-4. Condition of existing rigid pavement. The support that the existing rigid pavement will provide to an overlay is a function of its structural condition just prior to the overlay. In the overlay design equations, the structural condition of the existing rigid pavement is assessed by a condition factor  $C$ . The selection of a value of  $C$  is a judgment decision, which is somewhat arbitrary; however, to provide a more uniform assessment of the value, the following conditions are defined. Interpolation of  $C$  values between those shown may be used if it is considered necessary to more accurately define the existing structural condition.

a. Rigid overlay.

(1) Condition of existing JC pavement.

$C = 1.00$  - pavements in the trafficked areas are in good condition with little or no structural cracking due to load.

C = 0.75 - pavements in the trafficked areas exhibit initial cracking due to load but no progressive cracking or faulting of joints or cracks.

C = 0.35 - pavements in the trafficked areas exhibit progressive cracking due to load accompanied by spalling, raveling, or faulting of cracks and joints.

(2) Condition of existing JRC pavements.

C = 1.00 - pavements in the trafficked areas are in good condition with little or no short-spaced transverse (1- to 2-foot) cracks, no longitudinal cracking, and little spalling or raveling along cracks.

C = 0.75 - pavements in the trafficked areas exhibit short-spaced transverse cracking but little or no interconnecting longitudinal cracking due to load and only moderate spalling or raveling along cracks.

C = 0.35 - pavements in the trafficked areas exhibit severe short-spaced transverse cracking and interconnecting longitudinal cracking due to load, severe spalling along cracks, and initial punchout-type failures.

b. Nonrigid overlay.

(1) Condition of existing JC pavements.

C = 1.00 - pavements in the trafficked areas are in good condition with some cracking due to load but little or no progressive-type cracking.

C = 0.75 - pavements in the trafficked area exhibit progressive cracking due to load and spalling, raveling, and minor faulting at joints and cracks.

C = 0.50 - pavements in the trafficked areas exhibit multiple cracking along with raveling, spalling, and faulting at joints and cracks.

(2) Condition of existing JRC pavement.

C = 1.00 - pavements in trafficked areas are in good condition but exhibit some closely spaced

load-induced transverse cracking, initial interconnecting longitudinal cracks, and moderate spalling or raveling of joints and cracks.

C = 0.75 - pavements in trafficked areas exhibit numerous closely spaced load-induced transverse and longitudinal cracks, rather severe spalling or raveling, or initial evidence of punchout failures.

5-5. Rigid overlay of existing rigid pavement. There are two basic equations for the design of rigid overlays which depend upon the degree of bond that develops between the overlay and existing pavement: partially bonded and nonbonded. The partially bonded equation will be used when the rigid overlay is to be placed directly on the existing pavement. It requires the lesser thickness of overlay and will be used when possible. A bond-breaking medium and nonbonded equation will be used when a JC overlay is used to overlay an existing JRC pavement, when a JC overlay is being used to overlay an existing JC pavement that has a condition factor  $C \leq 0.35$ , and when matching joints in a JC overlay with those in the existing JC pavement causes undue construction difficulties or results in odd-shaped slabs.

a. JC overlay.

(1) Thickness determination. The required thickness  $h_{doc}$  of JC overlay will be determined from the following equations:

Partially bonded:

$$h_{doc} = 1.4 \sqrt[1.4]{h_{dc} - C \left( \frac{h_{dc}}{h_{dec}} h_{Ec} \right)^{1.4}}$$

Nonbonded:

$$h_{doc} = \sqrt[2]{h_{dc} - C \left( \frac{h_{dc}}{h_{dec}} h_{Ec} \right)^2}$$

where  $h_{dc}$  and  $h_{dec}$  are design thicknesses of JC pavement determined in accordance with paragraph 2-2 using the design flexural strength of the overlay and measured flexural strength of the existing rigid pavement, respectively; the modulus of soil reaction  $k$  of the existing rigid pavement foundation; and the design loading, traffic area, and pass level needed for overlay design. The ratio  $h_{dc}/h_{dec}$  is an adjustment factor used only when the difference in the flexural strength of the concrete overlay and existing rigid pavement exceeds 100 psi. The factor  $h_{Ec}$  represents the thickness of JC pavement equivalent to load-carrying capacity to the thickness of existing rigid pavement. If



9 Apr 84

the existing rigid pavement is JC ( $h_{ec}$ ), then  $h_{EC} = h_{ec}$ . However, if the existing rigid pavement is JRC ( $h_{er}$ ), the value of  $h_{EC}$  must be determined from figure 3-1 using the percent of reinforcing steel,  $S$ , and the thickness  $h_{er}$ . The minimum thickness of JC overlay will be 6 inches.

(2) Jointing. For all partially bonded JC overlays, joints will be provided in the overlay to coincide with all joints in the existing rigid pavement. It is not necessary for joints in the overlay to be of the same type as joints in the existing pavement. When it is impractical to match the joints in the overlay to joints in the existing rigid pavement, either a bond-breaking medium will be used and the overlay designed as a nonbonded overlay or the overlay will be reinforced over the mismatched joints in accordance with paragraph 3-3b. Should the mismatch of joints become severe, a JRC overlay design (b below) should be considered as an economic alternative to the use of a nonbonded JC overlay. For nonbonded JC overlays, the design and spacing of transverse contraction joints will be in accordance with paragraph 2-3a. For both partially bonded and nonbonded JC overlays, the longitudinal construction joints will be doweled using the dowel size and spacing given in table 2-2. Any contraction joint in the overlay that coincides with an expansion joint in the existing rigid pavement within the prescribed limits of a Type A traffic area will be doweled. Joint sealing for JC overlays will conform to the requirements of paragraph 2-3f.

b. JRC overlay. A JRC overlay may be used to strengthen either an existing JC or JRC pavement. Generally, the overlay will be designed as a partially bonded overlay. The nonbonded overlay design will be used only when a leveling course is required over the existing pavement. The reinforcement steel for JRC overlay will be designed and placed in accordance with paragraph 3-5.

(1) Thickness determination. The required thickness  $h_{dor}$  of JRC overlay will be determined using figure 3-1 after the thickness of JC overlay ( $h_{doc}$ ) has been determined using the appropriate overlay equation. Then, with a value for  $h_{doc}$ , either the thickness  $h_{dor}$  can be selected and the required percent steel,  $S$ , determined, or  $S$  can be selected and  $h_{dor}$  determined from figure 3-1. The minimum thickness of JRC overlay will be 6 inches.

(2) Jointing. Whenever possible, the longitudinal construction joints in the overlay should match the longitudinal joints in the existing pavement. All longitudinal joints will be of the butt-doweled type with dowel size and spacing designated in accordance with paragraph 2-3 using the thickness  $h_{dor}$ . It is not necessary for transverse joints in the overlay to match joints in the existing pavement; however, when practical, the joints should be matched. The maximum spacing of transverse contraction joints will be determined in accordance with figure 3-2 or paragraph 2-3a, but it will not exceed

9 Apr 84

100 feet regardless of thickness of pavement or percent steel used. Joint sealing for JRC pavements will conform to the requirements of paragraph 2-3f.

c. JFC overlay. A JFC overlay may be used to strengthen either an existing JC or JRC pavement. The mix proportioning of the JFC overlay will follow the considerations outlined in paragraph 4-3.

(1) Thickness determination. The required thickness  $h_{dof}$  of JFC overlay will be determined using the following equations. Normally, the partially bonded equation will be used; however, in cases of extremely faulted or uneven existing pavement surfaces, a leveling course may be required and the design of the overlay will be made using the nonbonded overlay equation.

Partially Bonded:

$$h_{dof} = 0.75 \sqrt[1.4]{h_{dc}^{1.4} - C \left( \frac{h_{dc}}{h_{dec}} h_{Ec} \right)^{1.4}}$$

Nonbonded:

$$h_{dof} = 0.75 \sqrt[2]{h_{dc}^2 - C \left( \frac{h_{dc}}{h_{dec}} h_{Ec} \right)^2}$$

where  $h_{dc}$  and  $h_{dec}$  are design thickness of JC pavement determined in accordance with paragraph 2-2 using the design flexural strength of the JFC overlay and flexural strength of the existing rigid pavement, respectively, the modulus of soil reaction  $k$  of the existing rigid pavement foundation, and the design loading, traffic area, and pass level needed for the overlay design. The ratio  $h_{dc}/h_{dec}$  will normally be required because the flexural strength of the JFC will generally exceed the flexural strength of the existing rigid pavement by more than 100 psi. The factor  $h_{Ec}$  represents the thickness of JC pavement equivalent to the thickness of the existing rigid pavement. If the existing rigid pavement is JC ( $h_{Ec}$ ), then  $h_{Ec} = h_{ec}$ ; however, if the existing rigid pavement is JRC ( $h_{er}$ ),  $h_{Ec}$  must be determined from figure 3-1 using the values of  $h_{er}$  and the percent of reinforcing steel,  $S$ . The minimum thickness of JFC overlay will be 4 inches.

(2) Jointing. In general, the joint types and designs discussed in paragraph 2-3 and the maximum spacing shown in paragraph 4-6 apply to JFC overlays. It is not essential that joints be provided in the JFC overlays to coincide with joints in the existing rigid pavement; however, the matching of longitudinal joints is desirable. Longitudinal construction joints will be the butt-doweled type, and dowels will be required in transverse contraction joints exceeding 50-foot spacings. Sealing of joints in JFC overlays will be in accordance with paragraph 4-6.

5-6. Rigid overlay of existing flexible or existing composite pavement. Any type of rigid overlay (JC, JRC, or JFC) may be used to strengthen an existing flexible or composite pavement. The existing pavement is considered to be a composite pavement when it is composed of a rigid base pavement that has been strengthened with 4 inches or more of nonrigid (flexible or all-bituminous) overlay. If the nonrigid overlay is less than 4 inches, the rigid overlay is designed using the nonbonded overlay equation as outlined in paragraph 5-5. The design of the rigid overlay will follow the procedures outlined in chapters 2 through 4 of this manual. The strength afforded by the existing pavement will be characterized by the modulus of soil reaction  $k$  performed in accordance with paragraph 1-9a but in no case will a  $k$  value greater than 500 psi per inch be used for design. When figure 1-3 is used to estimate the  $k$  value at the surface of the existing flexible pavement, the bituminous concrete portion will be assumed to be unbound base material.

5-7. Nonrigid overlay of existing rigid pavement. Two types of nonrigid overlay, all-bituminous concrete overlay and flexible overlay, may be used with certain reservations to strengthen an existing rigid pavement.

a. Thickness determination. Regardless of the type of nonrigid overlay, the required thickness  $t_o$  will be determined by the following equation:

$$t_o = 2.5(Fh_{dec} - Ch_{EC})$$

where  $h_{dec}$  is the design thickness of JC pavement determined from chapter 2 using the flexural strength  $R$  of the concrete in the existing rigid pavement, the modulus of soil reaction  $k$  of the existing pavement, and the overlay design class. The factor  $h_{EC}$  represents the thickness of JC pavement equivalent in load-carrying ability to the thickness of existing rigid pavement. If the existing rigid pavement is JC ( $h_{ec}$ ), then  $h_{EC} = h_{ec}$ ; however, if the existing rigid pavement is JRC ( $h_{er}$ ), the value of  $h_{EC}$  must be determined from figure 3-1 using the thickness  $h_{er}$  and the percentage of reinforcing steel,  $S$ .  $F$  is a factor, determined from figure 5-1, that projects the cracking that may be expected to occur in the base pavement during the design life of the overlay, and  $C$  is a coefficient based upon the structural condition of the existing rigid pavement (para 5-4). The computed value of  $t_o$  will be rounded to the nearest multiple of 1 inch. The minimum value of  $t_o$  used for strengthening purposes will be 2 inches for all Type D traffic areas and overruns, 3 inches for Types B and C traffic areas in light-load pavements, and 4 inches for all others. In certain instances, the nonrigid overlay design equation will indicate thickness requirements less (sometimes negative values) than the minimum values, and in such cases the minimum thickness requirement will be used.

9 Apr 84

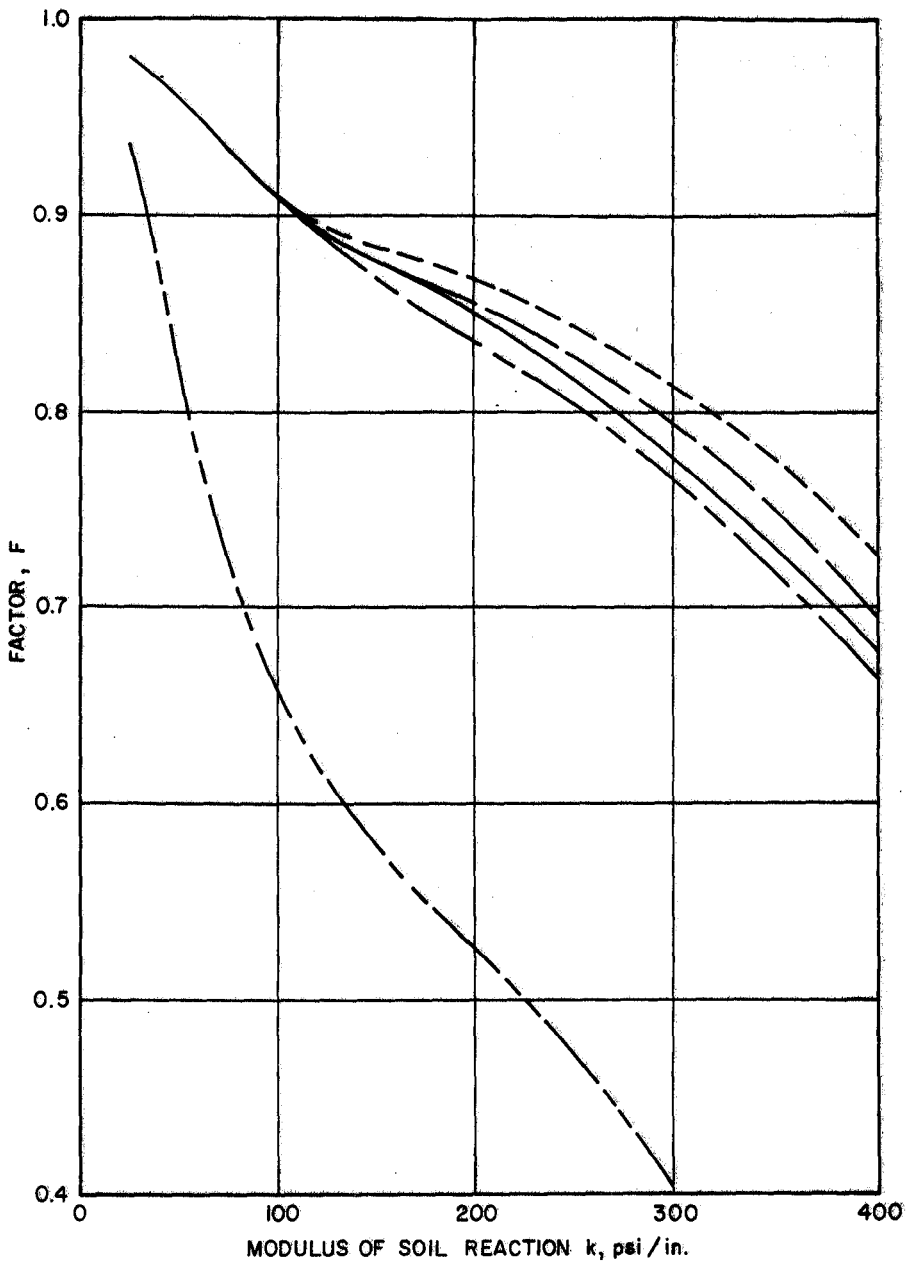

**LEGEND**

|           | <u>LOAD</u>      | <u>TRAFFIC AREAS</u>              |
|-----------|------------------|-----------------------------------|
| —————     | Heavy            | A, B, and C                       |
| - - - - - | Medium           | A, B, and C                       |
| - · - · - | Light            | B and C                           |
| - · - - - | Short fields     | A                                 |
| - · - · - | Heavy and Medium | D (and overruns<br>for all loads) |

NOTE: Minimum value of F = 0.40  
 for k > 400 use the F value  
 for k = 400

U. S. Army Corps of Engineers

FIGURE 5-1. CONDITION FACTOR F VERSUS MODULUS OF SOIL REACTION K

9 Apr 84

b. Alternate thickness design procedure. When strengthening existing rigid pavements that exhibit low flexural strength (less than 500 psi) or that are constructed on high-strength foundations ("k" exceeding 200 psi per inch), it is found that the flexible pavement design procedure in EM 1110-3-141 may indicate a lesser required overlay thickness than the overlay design formula in paragraph a. above. For these conditions, the overlay thickness will be determined by both methods, and the lesser thickness used for design. For the flexible pavement design procedure, the existing rigid pavement will be considered to be either an equivalent thickness of all-bituminous concrete (equivalency factor of 1.15 for base and 2.3 for subbase), and the total pavement thickness determined based upon the subgrade CBR. Any existing base or subbase layers will be considered as corresponding layers in the flexible pavement. The thickness of required overlay will then be the difference between the required flexible pavement thickness and the combined thicknesses of existing rigid pavement and any base or subbase layers above the subgrade.

c. All-bituminous overlay. The all-bituminous overlay will be composed of hot-mix bituminous concrete. A tack coat is required between the existing rigid pavement and the overlay. The all-bituminous overlay is the preferred nonrigid type overlay to lessen the danger of entrapped moisture in the overlay.

d. Flexible overlay. The flexible overlay will be composed of hot-mix bituminous concrete and high-quality (CBR = 100) crushed aggregate base provided positive drainage of the base course is achieved. The bituminous concrete will meet the minimum thickness requirements of EM 1110-3-141. The crushed aggregate base will have a minimum thickness of 4 inches. If the design thickness  $t_o$  of nonrigid overlay is less than that required by the minimum thickness of bituminous concrete and base course, the overlay will be designed as an all-bituminous overlay.

e. Jointing. Normally, joints, other than those required for construction of a bituminous concrete pavement, will not be required in nonrigid overlays of existing rigid pavements. It has been experienced that the lower viscosity (or higher penetration grade) asphalts are less likely to experience reflection cracking at joints. Therefore, the lowest viscosity grade asphalt that will provide sufficient stability during high temperatures should be used.

5-8. Overlays in frost regions. Whenever the subgrade is subject to frost action, the design will meet the requirements for frost action stated in EM 1110-3-138. The design will conform to frost requirements for rigid pavements. If subgrade condition will produce detrimental nonuniform frost heaving, overlay pavement design will not be considered unless the combined thickness of overlay and existing pavement is sufficient to prevent substantial freezing of the subgrade.

## CHAPTER 6

### RIGID PAVEMENT INLAY DESIGN

6-1. General. A method commonly used to rehabilitate distressed facilities is to construct an adequately designed rigid pavement inlay section in the center of the facility. These inlays are generally 50 feet wide for taxiways and 75 feet wide for runways; however, the widths will be influenced by the lateral traffic distribution and, in existing rigid pavements, by the joint configuration. The inlay pavement may consist of any type of rigid pavement discussed in chapters 2 through 4. The thickness design of the rigid inlay will be the same as outlined in chapters 2 through 4 except for special requirements presented herein. Because of the mobilization nature of this type of rehabilitation program, some design requirements may be waived and rapid construction procedures may be required as outlined herein.

6-2. Rigid inlays in existing flexible pavement. Figure 6-1 shows a section of a typical rigid pavement inlay in an existing flexible pavement.

a. Removal of the existing flexible pavement will be held to the absolute minimum. The depth of the excavation will not exceed the design thickness of the rigid pavement inlay. The width of the excavation of the existing pavement will not exceed the required width of the inlay section plus the minimum necessary, approximately 3 feet, for forming or slipforming the edges of the concrete pavement (fig 6-1).

b. Subdrains will be considered only when they are essential to the construction of the inlay section. When required, the subdrains will be placed outside of the edge of the rigid inlay and at least 4 inches below the bottom of the inlay pavement to permit construction of the stabilized layer required in paragraph c. below.

c. Unless the materials in the bottom of the excavation are granular and free-draining or the airfield is located in an arid climate, the bottom full width of the excavation will be scarified to a minimum depth of 4 inches, stabilized with chemicals or bitumens, and recompacted to the density requirements for the top 6 inches of base course or subgrade as specified previously. Reference should be made to EM 1110-3-137 for selection of stabilizing agents and minimum strength requirements.

d. The modulus of soil reaction  $k$  used for the design of the rigid pavement relay will be determined on the surface of the material at the bottom of the excavation prior to stabilization. If the strength of the stabilized material does not meet the

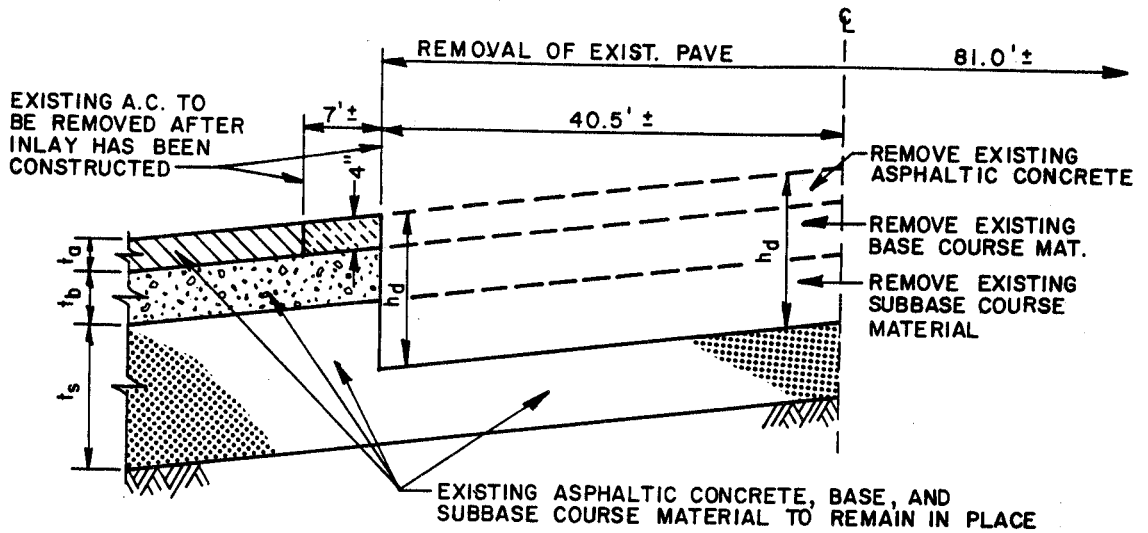

TRANSVERSE SECTION SHOWING REMOVAL OF EXISTING FLEXIBLE PAVEMENT FOR RIGID PAVEMENT INLAY SECTION RUNWAYS

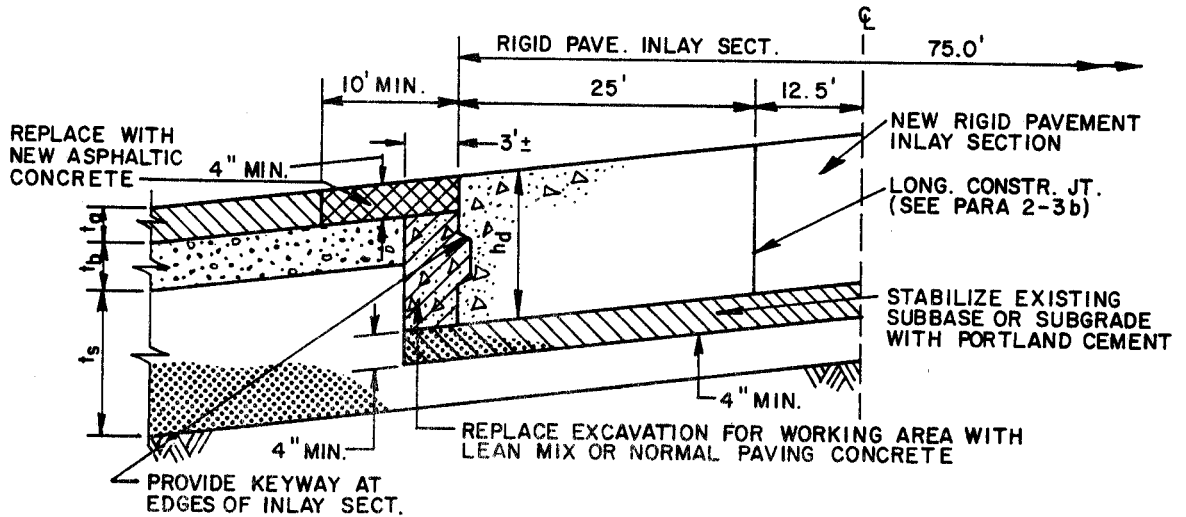

TRANSVERSE SECTION SHOWING CONSTRUCTION OF RIGID PAVEMENT INLAY SECTION IN RUNWAYS

**LEGEND**

- $h_d$  Design thickness of rigid pavement
- $t_o$  Thickness of existing bituminous concrete
- $t_b$  Thickness of existing base-course material
- $t_s$  Thickness of existing subbase-course material

NOTE: Sections shown are for 75 foot wide inlays; construction of 100 foot wide inlays will be handled in a similar manner.

U. S. Army Corps of Engineers

FIGURE 6-1. TYPICAL 75-FOOT-WIDE RIGID PAVEMENT INLAY IN EXISTING FLEXIBLE PAVEMENT

requirements in EM 1110-3-137 for pavement thickness reduction, no structural credit will be given to the stabilized material in the design of the rigid pavement inlay. If the strength of the stabilized layer meets the minimum strength requirement for pavement thickness reduction in EM 1110-3-137, the rigid pavement inlay will be designed in accordance with applicable sections of chapters 2 through 4 pertaining to the use of stabilized soil layers.

e. If the existing pavement is not composed of a depth of nonfrost-susceptible materials sufficient to eliminate substantial frost penetration into an underlying frost-susceptible material, an appropriate reduction in the k value will be made in accordance with EM 1110-3-138. In these cases, the inlay will be designed as a JRC pavement (chap 3) using a minimum of 0.15 percent steel. The pavement thickness may be reduced and longer slabs may be used as applicable to the design of JRC pavements.

f. After the construction of the rigid pavement inlay, the working areas used for forming or slipforming the sides of the concrete will be backfilled to within 4 inches of the pavement surface with either lean-mix (Econcrete) or normal paving concrete.

g. The existing bituminous concrete will be sawed parallel to and at a distance of 10 feet from each edge of the inlay. The bituminous concrete surface and binder courses and, if necessary, the base course will be removed to provide a depth of 4 inches. The exposed surface of the base course will be recompact, and a 10-foot-wide paving lane of bituminous concrete, 4 inches thick, will be used to fill in the gap (fig 6-1).

h. In cases where the 10-foot width of new bituminous concrete at either side of the inlay section does not permit a reasonably smooth transition from the inlay to the existing pavement, additional leveling work outside of the 10-foot lane will be accomplished by removal and replacement, planer operation, or both.

6-3. Rigid inlays in existing rigid pavement. Figure 6-2 shows a section of a typical rigid pavement inlay in an existing rigid pavement.

a. The existing rigid pavement will be removed to the nearest longitudinal joints that will provide the design width of the rigid pavement inlay. Care will be exercised in the removal of the existing rigid pavement to preserve the load-transfer device (key, keyway, or dowel) in the longitudinal joint at the edge of the new inlay pavement. If the existing load-transfer devices can be kept intact, they will be used to provide load transfer between the rigid pavement inlay and the existing pavement. If the load transfer devices are damaged or destroyed, the undercut joint shown in figure 2-10 or 3-5 should be used to protect against edge loading of the existing pavement. In



9 Apr 84

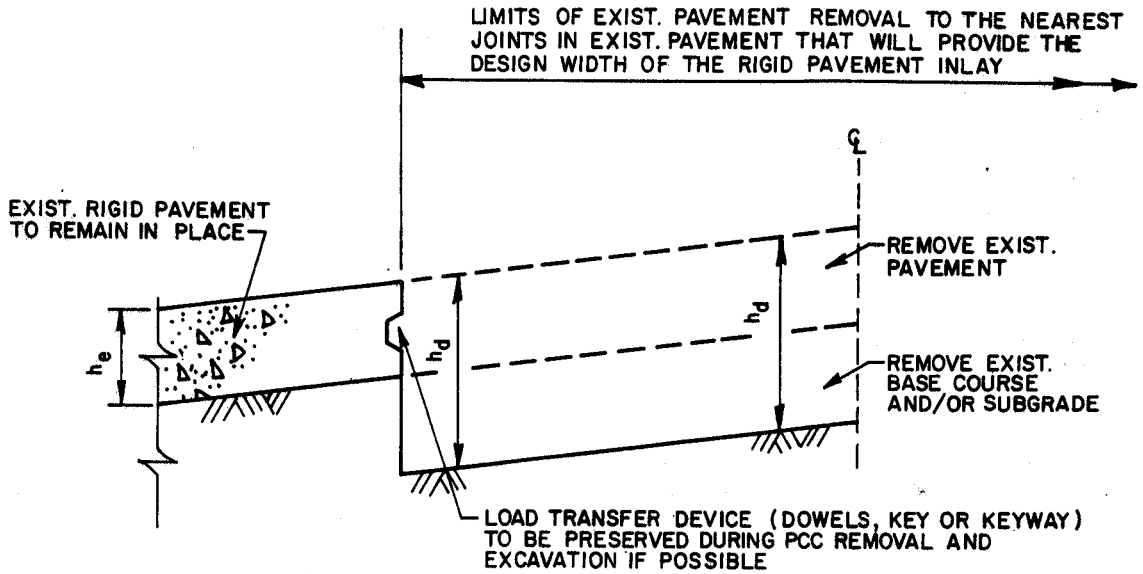

TRANSVERSE SECTION SHOWING REMOVAL OF EXISTING RIGID PAVEMENT FOR RIGID PAVEMENT INLAY SECTION

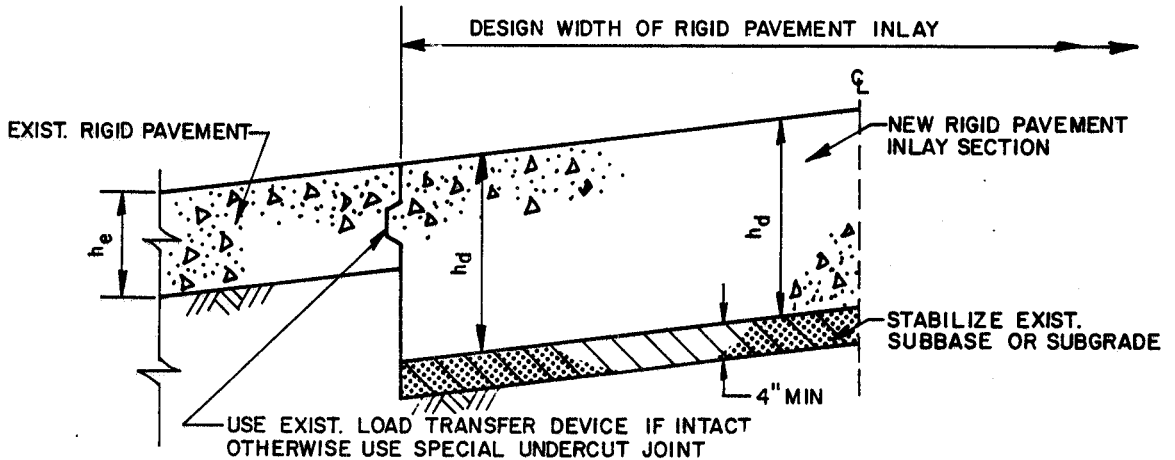

TRANSVERSE SECTION SHOWING CONSTRUCTION OF RIGID PAVEMENT INLAY SECTION

**LEGEND**

- $h_d$  Design thickness of rigid pavement for inlay
- $h_e$  Thickness of existing pavement

U. S. Army Corps of Engineers

FIGURE 6-2. TYPICAL RIGID PAVEMENT INLAY IN EXISTING RIGID PAVEMENT

9 Apr 84

addition to the removal of the existing pavement, the existing base and/or subgrade will be removed to the depth required to the design thickness of the rigid pavement inlay.

b. Paragraphs 6-2b through 6-2e also pertain to rigid pavement inlays in existing rigid pavements.

c. The design of the rigid pavement inlay, including joint types and spacing, will be in accordance with the chapter pertaining to the type of rigid pavement selected.

APPENDIX A

REFERENCES

Government Publications.

Department of Defense.

- |                              |  |
|------------------------------|--|
| MIL-STD-619B                 | Unified Soil Classification System for Roads, Airfields, Embankments, and Foundations. |
| MIL-STD-621A<br>Notices 1, 2 | Test Method for Pavement Subgrade, Subbase, and Base-Course Materials.                 |

Department of the Army.

- |               |  |
|---------------|--|
| EM 1110-3-135 | Standard Practice for Concrete Pavements.        |
| EM 1110-3-136 | Drainage and Erosion Control.                    |
| EM 1110-3-137 | Soil Stabilization for Pavements.                |
| EM 1110-3-138 | Pavement Criteria for Seasonal Frost Conditions. |
| EM 1110-3-141 | Airfield Flexible Pavement.                      |

Nongovernment Publications.

American Society for Testing and Materials (ASTM), 1916 Race Street, Philadelphia, PA 19103

- |                     |   |
|---------------------|---|
| C 78-75<br>(R 1982) | Flexural Strength of Concrete (Using Simple Beam with Third-Point Loading). |
| E 11-81             | Wire-Cloth Sieves for Testing Purposes.                                     |